

## TPS63710 低噪声同步反相降压转换器

### 1 特性

- 输入电压范围为 3.1V 至 14V
- 输出电流为 1A
- 效率高达 91%
- 输出电压精度为  $\pm 1.5\%$
- 同步整流
- 低 1/f 噪声参考系统
- 噪音:  $22\mu\text{V}_{\text{RMS}}$  (10Hz 至 100kHz)
- 输出电压: -1V 至 -5.5V
- $|V_{\text{OUT}}| < 0.7 \times V_{\text{IN}}$
- 1.5MHz 固定频率 PWM 模式
- 热关断
- 5 $\mu\text{A}$  关断电流
- 3mm x 3mm WSON 封装
- 使用 TPS63710 并借助 [WEBENCH®](#) 电源设计器创建定制设计方案

### 2 应用

- 通用负电压电源
  - 电信系统中的 ADC 和 DAC 电源
  - GaN 晶体管偏压
  - 光学模块激光二极管偏压
  - 需要负电源电压的噪声敏感型和空间受限型应用
- 典型应用

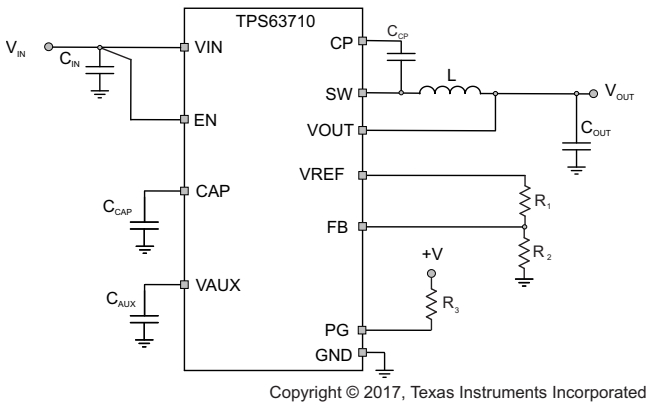

### 3 说明

TPS63710 作为反相降压直流/直流转换器，可产生低至 -5.5V 的负输出电压。它提供高达 1A 的输出电流，具体值取决于输入电压与输出电压比。其经过滤波的参考系统提供高性能电信系统中所需的低 1/f 噪声。

TPS63710 采用固定频率的 PWM 控制拓扑。它具有内部电流限制和热关断功能。TPS63710 具有 3.1V 至 14V 的输入电压范围，因此可用于需要从较高的正输入电压（绝对值）产生负输出电压的各种应用。

同步整流提供高效率，特别是对于小输出电压（如 -1.8V，此类电压通常用作高性能 DAC 和 ADC 的负电源电压）。该器件具有 1.5MHz 的固定开关频率，因此允许使用小型外部组件，并可实现较小的总体解决方案尺寸。

TPS63710 采用 3mm x 3mm WSON 封装，能够为高环境温度下运行的应用提供良好的散热性能。

器件信息<sup>(1)</sup>

器件型号	封装	封装尺寸（标称值）
TPS63710	WSON	3mm x 3mm

(1) 如需了解所有可用封装，请参阅产品说明书末尾的可订购产品附录。

$V_{\text{OUT}} = -1.8\text{V}$  时效率与输出电流间的关系

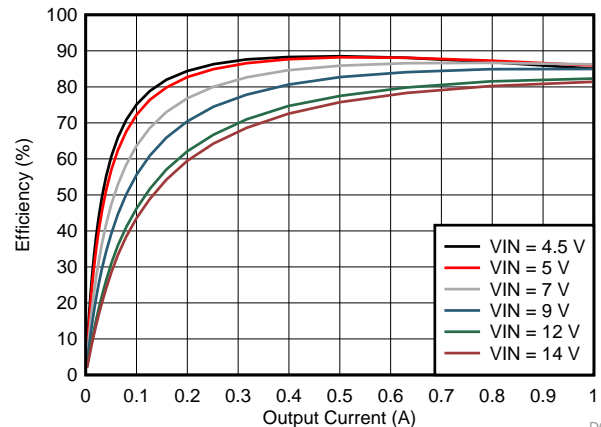

## 目录

<b>1</b>	特性 .....	1	7.4	Device Functional Modes.....	10
<b>2</b>	应用 .....	1	<b>8</b>	<b>Application and Implementation</b> .....	12
<b>3</b>	说明 .....	1	8.1	Application Information.....	12
<b>4</b>	修订历史记录 .....	2	8.2	Typical Application .....	12
<b>5</b>	<b>Pin Configuration and Functions</b> .....	3	8.3	System Examples .....	22
<b>6</b>	<b>Specifications</b> .....	4	<b>9</b>	<b>Power Supply Recommendations</b> .....	24
6.1	Absolute Maximum Ratings .....	4	<b>10</b>	<b>Layout</b> .....	25
6.2	ESD Ratings .....	4	10.1	Layout Guidelines .....	25
6.3	Recommended Operating Conditions.....	5	10.2	Layout Example .....	25
6.4	Thermal Information .....	5	<b>11</b>	<b>器件和文档支持</b> .....	26
6.5	Electrical Characteristics.....	6	11.1	器件支持 .....	26
6.6	Typical Characteristics.....	7	11.2	社区资源.....	26
<b>7</b>	<b>Detailed Description</b> .....	8	11.3	商标.....	26
7.1	Overview .....	8	11.4	静电放电警告.....	26
7.2	Functional Block Diagram .....	8	11.5	术语表 .....	26
7.3	Feature Description.....	9	<b>12</b>	<b>机械、封装和可订购信息</b> .....	26

## 4 修订历史记录

### Changes from Original (September 2017) to Revision A

**Page**

•	新增特性: 噪音: $22\mu V_{RMS}$ (10Hz 至 100kHz) .....	1
•	Changed 图 31 to 图 34 .....	18
•	Added 图 35 and 图 36 .....	19
•	Changed 图 41 .....	20

## 5 Pin Configuration and Functions

**DRR Package  
12-Pin WSON  
Top View**

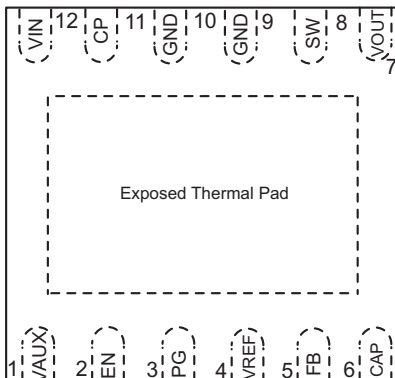

**Table 1. Pin Functions**

Pin		I/O	Description
Name	No.		
VIN	12	I	Power supply Input. Connect the input capacitor from this pin to GND and place it as close as possible to the device pins.
VAUX	1	O	Connect the output capacitor of the internal voltage regulator from this pin to GND. VAUX can be loaded externally with up to 100uA. Do not use this pin for any pulsed load to not couple noise into the internal supply.
GND	10, 9		Ground Connection. Voltages and signals are referenced to this pin.
CP	11	O	Connect a capacitor from this pin to SW.
SW	8	O	Connect a capacitor from this pin to CP and the inductor from this pin to the output.
FB	5	I	Feedback pin for the voltage divider.
VOUT	7	I	Output voltage sense pin.
CAP	6	O	Reference system bypass capacitor connection. Do not tie anything other than a capacitor to GND to this pin. Keep any noise sources away from this pin. The capacitor connected to this pin forms a low-pass filter with an internal filter resistor and also defines the soft-start time.
VREF	4	O	Reference voltage output. Connect a voltage divider between this pin, FB and GND to set the output voltage. Do not connect any other circuitry to this pin.
EN	2	I	Enable pin. The device is enabled when the pin is connected to a logic high level e.g. VIN. The device is disabled when the pin is connected to a logic low level. The logic levels are referenced to the IC's GND pin.
PG	3	O	Open drain power good output. Connect with a pull-up resistor to a positive voltage up to 5.5 V. If not used, leave open or connect to GND.
Exposed Thermal Pad	-	-	The thermal pad must be tied to GND. The pad must be soldered to a GND plane to achieve an appropriate thermal resistance and for mechanical reliability.

## 6 Specifications

### 6.1 Absolute Maximum Ratings<sup>(1)</sup>

	PIN	MIN	MAX	UNIT
Voltage <sup>(2)</sup>	VIN, EN	-0.3	15	V
	CP (DC)	-0.5	15	V
	CP (AC, less than 10ns) <sup>(3)</sup>	-3	17	V
	SW (DC)	-16	0.3	V
	SW (AC, less than 10ns) <sup>(3)</sup>	-20	1	V
	VAUX, PG	-0.3	5.5	V
	FB	-3.6	0.3	V
	VOUT	-6	0.3	V
	VREF, CAP	-5.5	0.3	V
Sink Current	PG		5	mA
Operating junction temperature, T <sub>J</sub>		-40	150	°C
Storage temperature, T <sub>stg</sub>		-65	150	°C

- (1) Stresses beyond those listed under *Absolute Maximum Ratings* may cause permanent damage to the device. These are stress ratings only, which do not imply functional operation of the device at these or any other conditions beyond those indicated under *Recommended Operating Conditions*. Exposure to absolute-maximum-rated conditions for extended periods may affect device reliability.
- (2) All voltages are with respect to network GND pin.
- (3) While switching

### 6.2 ESD Ratings

			VALUE	UNIT
V <sub>(ESD)</sub>	Electrostatic discharge	Human-body model (HBM), per ANSI/ESDA/JEDEC JS-001 <sup>(1)</sup>	±2000	V
		Charged-device model (CDM), per JEDEC specification JESD22-C101 <sup>(2)</sup>	±500	

- (1) JEDEC document JEP155 states that 500-V HBM allows safe manufacturing with a standard ESD control process.
- (2) JEDEC document JEP157 states that 250-V CDM allows safe manufacturing with a standard ESD control process.

### 6.3 Recommended Operating Conditions

		MIN	NOM	MAX	UNIT
V <sub>IN</sub>	Supply Voltage Range	3.1		14	V
	Supply voltage slew rate for a V <sub>IN</sub> step of less than 1V	-1		1	V/μs
	Supply voltage slew rate for a V <sub>IN</sub> step of greater or equal than 1V	-0.1		0.1	V/μs
I <sub>OUT</sub>	Output Current	-1		0	A
	duty cycle ≤ 70%				
L	Effective Inductance	1.5	2.2	6.2	μH
C <sub>OUT</sub>	Effective Output Capacitance <sup>(1)</sup> for T <sub>j</sub> = -20°C to 125°C	15	44	100	μF
C <sub>OUT</sub>	Effective Output Capacitance <sup>(1)</sup> for T <sub>j</sub> = -40°C to 125°C	22	44	100	μF
C <sub>IN</sub>	Effective Input Capacitance <sup>(1)</sup>	2 x C <sub>CP</sub>			μF
C <sub>CP</sub>	Effective Capacitance on the CP pin required for full output current at ≤ 70% duty cycle <sup>(1) (2)</sup>	4	4.7	20 <sup>(3)</sup>	μF
C <sub>AUX</sub>	Effective Capacitance from VAUX pin to GND <sup>(1)</sup>	0.08	0.22	1	μF
C <sub>CAP</sub>	Effective Capacitance from CAP pin to GND <sup>(1)</sup>	0.01		10	μF
R	Total resistance for R1 + R2 from VREF to GND	100		500	kΩ
T <sub>J</sub>	Operating Junction Temperature	-40		125	°C

- (1) The values given for all the capacitors are effective capacitance, which includes the dc bias effect. Especially the input capacitor C<sub>IN</sub> and the C<sub>CP</sub> capacitor, which are charged to the input voltage, are strongly effected. Their effective capacitance is much lower based on the dc voltage applied. Therefore, the nominal capacitor value needs to be larger than the minimum values given in the table. Please check the manufacturer's dc bias curves for the effective capacitance vs dc voltage applied.
- (2) If a maximum output current below 1A is required, the capacitance can be reduced accordingly. See the application section for details.
- (3) The maximum value also includes dc bias at the nominal operating voltage. During start-up when the voltage is 0 V, the effective capacitance can be higher. Please see the application section for details.

### 6.4 Thermal Information

THERMAL METRIC <sup>(1)</sup>		TPS63710	UNIT
		DRR (WSON)	
		12 PINS	
R <sub>θJA</sub>	Junction-to-ambient thermal resistance	44.3	°C/W
R <sub>θJC(top)</sub>	Junction-to-case (top) thermal resistance	47.7	°C/W
R <sub>θJB</sub>	Junction-to-board thermal resistance	18.9	°C/W
ψ <sub>JT</sub>	Junction-to-top characterization parameter	0.4	°C/W
ψ <sub>JB</sub>	Junction-to-board characterization parameter	19.1	°C/W
R <sub>θJC(bot)</sub>	Junction-to-case (bottom) thermal resistance	5.8	°C/W

- (1) For more information about traditional and new thermal metrics, see the *Semiconductor and IC Package Thermal Metrics* application report, [SPRA953](#).

## 6.5 Electrical Characteristics

$T_J = -40^{\circ}\text{C}$  to  $125^{\circ}\text{C}$ , over recommended input voltage range. Typical values are at  $V_{IN} = 5\text{ V}$  and  $T_J = 25^{\circ}\text{C}$  (unless otherwise noted)

PARAMETER		TEST CONDITIONS	MIN	TYP	MAX	UNIT
<b>SUPPLY</b>						
$I_{(Q)}$	Quiescent supply current	$I_{OUT} = 0\text{mA}$ , EN = high		15		mA
$I_{SD}$	Shutdown supply current	EN = low, $T_J = -40^{\circ}\text{C}$ to $85^{\circ}\text{C}$ <sup>(1)</sup>		5	25	$\mu\text{A}$
$I_{SD}$	Shutdown supply current	EN = low, $T_J = -40^{\circ}\text{C}$ to $125^{\circ}\text{C}$ <sup>(1)</sup>			55	$\mu\text{A}$
$V_{UVLO}$	Undervoltage lockout threshold	$V_{IN}$ falling, detected at VAUX	2.55	2.6	2.7	V
	Undervoltage lockout hysteresis	$V_{IN}$ rising, detected at VAUX	250		350	mV
$T_{SD}$	Thermal shutdown temperature	Junction temperature rising		160		$^{\circ}\text{C}$
	Thermal shutdown hysteresis	Junction temperature falling		20		$^{\circ}\text{C}$
<b>CONTROL (EN, PG)</b>						
$V_{IH}$	High level input voltage for EN		1		14	V
$V_{IL}$	Low level input voltage for EN				0.4	V
$I_{IN}$	Input current for EN	EN = high		0.01	0.1	$\mu\text{A}$
$R_{IN}$	Input resistance for EN	EN = low		400		k $\Omega$
	PG de-glitch time	rising or falling		10		$\mu\text{s}$
$V_{OL\_PG}$	PG output low voltage	$I_{PG} = 1\text{ mA}$		0.07	0.3	V
$I_{LKG\_PG}$	Input leakage current (PG)	$V_{PG} = 5\text{ V}$			100	nA
$V_{VAUX}$	Voltage at VAUX	$V_{IN} \geq 5\text{ V}$ , $I_{VAUX} = 100\ \mu\text{A}$		4.6		V
$I_{VAUX}$	Current drawn from VAUX		0		100	$\mu\text{A}$
<b>POWER SWITCH</b>						
$I_{LIM}$	Switch current limit (LSD)	$4\text{ V} \leq V_{IN} < 14\text{ V}$ , duty cycle $\leq 70\%$	1.4	2.1	3	A
$I_{LIM}$	Switch current limit (LSD)	$3.1\text{ V} < V_{IN} < 4\text{ V}$ , duty cycle $\leq 70\%$	0.8			A
$R_{DS(ON)}$	Switch on-resistance	HSD switch, $V_{IN} \geq 5\text{ V}$		80	130	m $\Omega$
		LSD switch, $V_{IN} \geq 5\text{ V}$		120	190	
		RECT switch, $V_{IN} \geq 5\text{ V}$		40	80	
$D_{MAX}$	Maximum duty cycle	at SW pin		70%		
$t_{on,min}$	Minimum on-time			130		ns
$f_S$	Switching frequency		1400	1500	1600	kHz
<b>OUTPUT</b>						
$V_{OUT}$	Output voltage range	$ V_{OUT}  < 0.7 \times V_{IN}$	-5.5		-1	V
$V_{FB}$	FB regulation voltage			-0.7 <sup>(2)</sup>		V
	Output voltage tolerance <sup>(3)</sup>	for $V_{OUT} \leq -1.8\text{ V}$	-1.5%		1.5%	
	Output voltage tolerance <sup>(3)</sup>	for $-1.8\text{ V} < V_{OUT} \leq -1\text{ V}$	-2%		1.5%	
$I_{FB}$	Feedback input bias current	$V_{FB} = -0.7\text{ V}$		2	100	nA
$R_{DIS}$	Discharge resistance from pin VOUT to GND	EN = low		100		$\Omega$
	Line regulation			0.05		%/A
	Load regulation			0.02		%/V
$t_{delay}$	Start-up delay time from EN = high to start switching	with $C_{CP} = 10\ \mu\text{F}$		5		ms
$t_{ramp}$	Ramp time from start switching until device has reached 95% of its nominal output voltage	$C_{CAP} = 47\text{ nF}$ , $V_{OUT} = -1.8\text{ V}$ , device not in current limit during start-up		1		ms
$I_{ramp}$	Soft-start current into $C_{CAP}$		55	100	145	$\mu\text{A}$

(1) This specification applies after there has been a high to low transition on EN. If EN is low while the supply voltage is applied, the shutdown current can be up to  $90\ \mu\text{A}$ .

(2) Please see the application section for how to set the output voltage.

(3) Tolerance of  $V_{FB}$  voltage and error of gain stage - see also "Low Noise Reference System"

### 6.6 Typical Characteristics



图 2. EN Threshold, rising  $V_{IN}$



图 3. EN Threshold, falling  $V_{IN}$

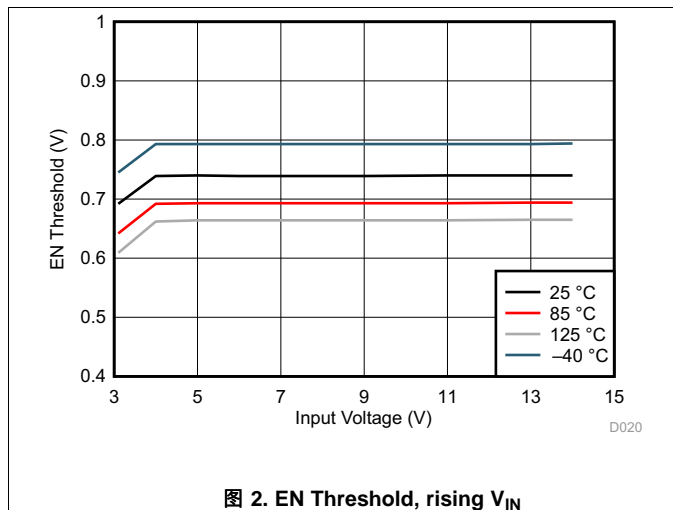

图 4. EN Threshold Hysteresis

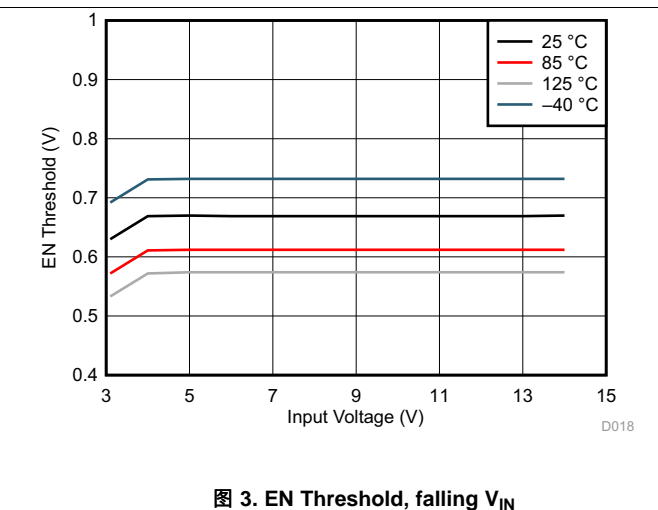

图 5. Resistance of HSD

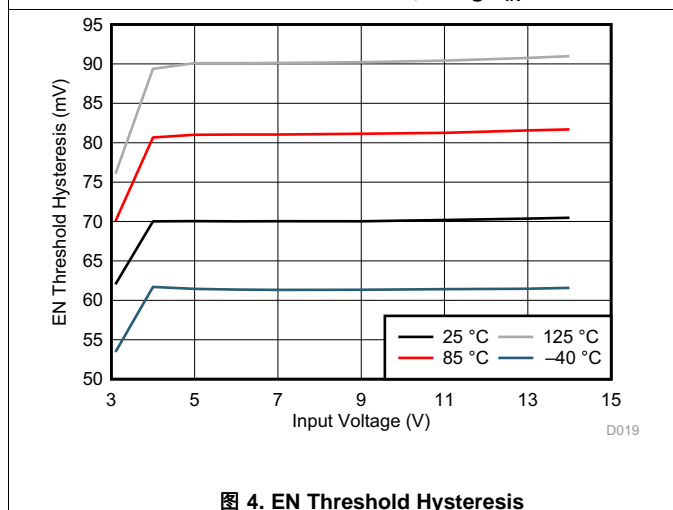

图 6. Resistance of LSD

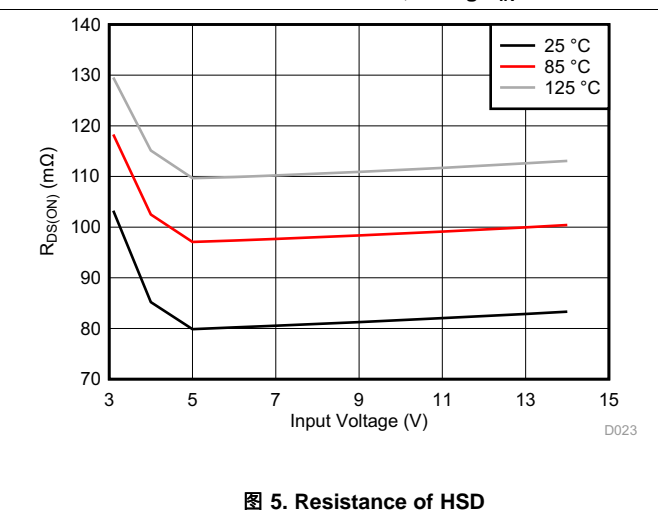

图 7. Resistance of RECT

## 7 Detailed Description

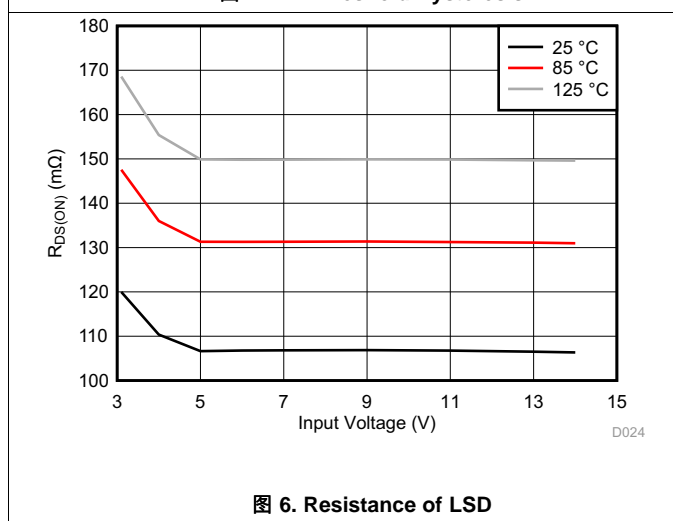
### 7.1 Overview

The TPS63710 is a dc-dc converter that generates a negative output voltage using an inverting buck topology. It operates with an input voltage range of 3.1 V to 14 V and generates a negative output voltage down to -5.5 V. As it is based on a step-down topology, the input voltage needs to be larger than the negative voltage, in absolute value, that is generated. The output is controlled by a fixed-frequency, pulse-width-modulated (PWM) regulator. As there is an inductor in the output path, similar to a step-down converter, the output current is continuous and the output voltage ripple is low. This makes this topology a perfect solution for noise sensitive applications.

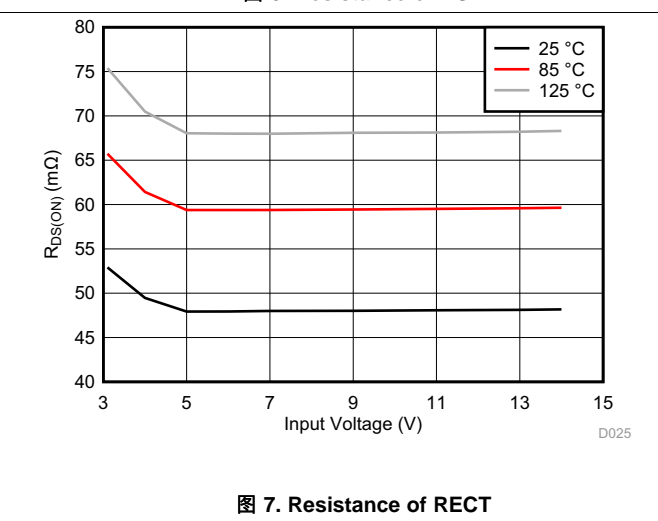
### 7.2 Functional Block Diagram

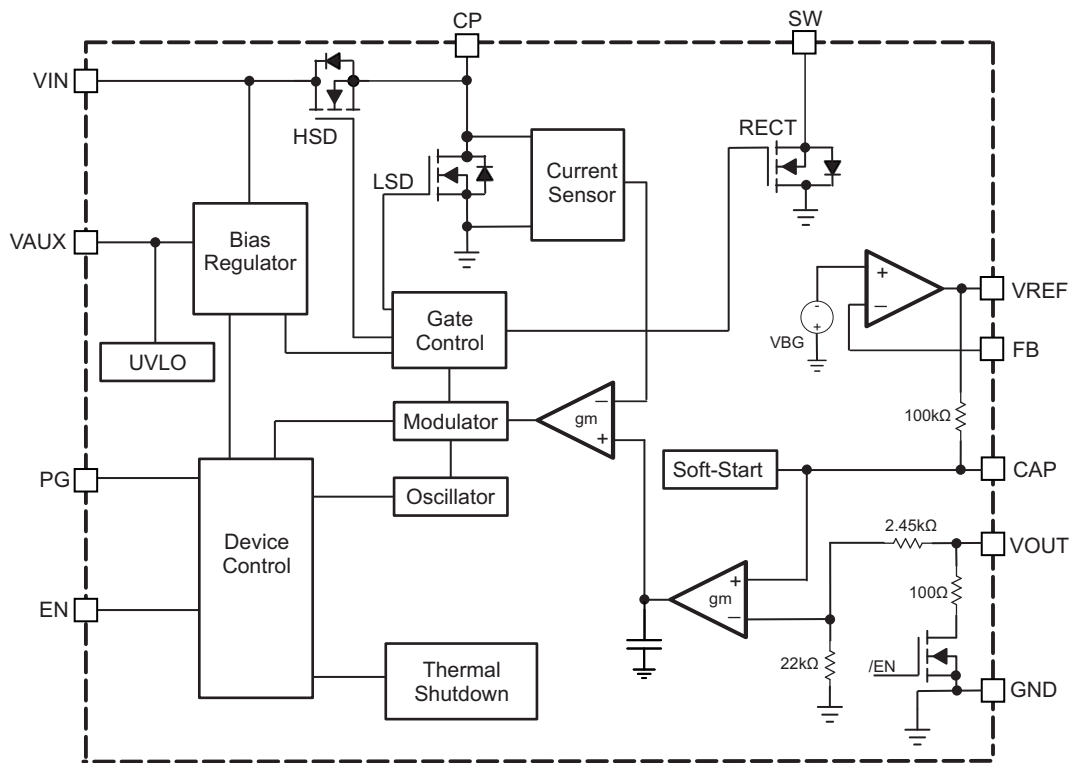

Copyright © 2017, Texas Instruments Incorporated

**图 8. Block Diagram**

## 7.3 Feature Description

### 7.3.1 Low Noise Reference System

The reference system in the TPS63710 uses an external filter capacitor on the CAP pin. This reduces the low-frequency (1/f) noise in a range from a lower limit up to around 100kHz. The lower limit is defined by the corner frequency of the RC filter from the internal 100-kΩ resistor and an external capacitor on the CAP pin. The corner frequency is defined by [公式 1](#).

$$f_c = \frac{1}{2\pi \times R \times C} = \frac{1}{2\pi \times 100k\Omega \times C_{CAP}} \quad (1)$$

In order to minimize the noise on the output voltage, the TPS63710 uses an architecture where the output voltage setting is done by changing the reference voltage which then is filtered. The gain stage therefore does not have to have a large gain in order to not increase the noise level. VBG is the internal bandgap reference voltage, optimized for low noise. Its output voltage is amplified and inverted and then filtered. The voltage on the CAP pin is the reference for the gain stage. The connection from CAP to the external capacitor should be as short as possible and be kept away from noisy traces. The gain stage has a small gain of 1/0.9. The voltage at VREF is negative and lower than the output voltage by the gain factor of the gain stage. Please also see [Setting the Output Voltage](#). [图 9](#) shows the low noise architecture.



图 9. Low Noise Architecture

### 7.3.2 Duty Cycle

The duty cycle referred to in this data sheet is the duty cycle at the SW pin. By definition, from the PWM operation, the CP pin has the inverse duty cycle of 1-D. As a first approximation, the duty cycle is defined as  $|V_{OUT}| / V_{IN}$ . However, the actual duty cycle is larger, due to losses, and must remain below 70% for a robust design.

### 7.3.3 Enable

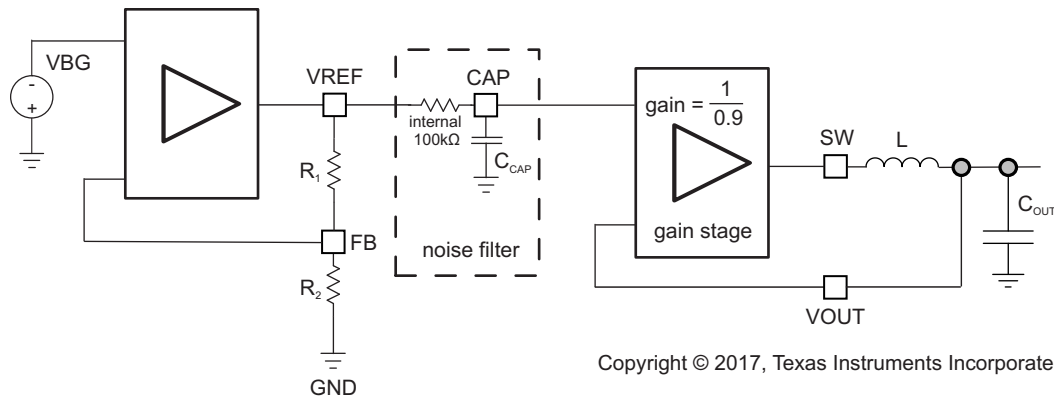
The device is enabled when the EN pin is set to high. With EN set to low, the device shuts down. After EN is set high, the capacitor  $C_{CP}$  (from CP to SW) is pre-charged with about 50mA. After the start-up delay time  $t_{delay}$ , the device starts switching and ramps the output voltage to its target value. See [Soft-Start](#).

The EN pin must be set externally to high or low. An internal pull-down resistor of about 400 kΩ is connected and keeps EN low, if a low is detected internally and afterwards the pin is floating. When a high level is detected, the internal resistor is disconnected. The logic levels are referenced to the IC's GND pin.

### 7.3.4 Undervoltage Lockout

An undervoltage lockout circuit prevents the device from starting up and operating, if the supply voltage is too low. The device automatically shuts down the converter when the  $V_{AUX}$  voltage falls below the  $V_{UVLO}$  threshold. There is hysteresis to prevent oscillation with high impedance supply voltage sources. Once the threshold plus hysteresis is exceeded, the device enters soft-start. Undervoltage lockout is sensed on the  $V_{AUX}$  voltage, as this is the internal supply for the control loop and logic.

## Feature Description (接下页)

When  $V_{IN}$  ramps down to a voltage too low to maintain the desired output voltage, the absolute value of the output voltage drops and the power good output goes low. When the output voltage level reaches the voltage on  $C_{CAP}$ , at about 90% of the target output voltage, the device shuts down and initiates a re-start cycle. The TPS63710 then stays in the start-up state, until the input voltage is high enough to reach the desired output voltage.

### 7.3.5 Thermal Shutdown

The junction temperature ( $T_J$ ) of the device is monitored by an internal temperature sensor. If  $T_J$  exceeds the thermal shutdown temperature  $T_{SD}$ , the device turns off the internal power FETs, discharges the output capacitor and the power good output goes low. It starts operation again when the junction temperature has decreased by the thermal shutdown hysteresis.

### 7.3.6 Power Good Output

The TPS63710 has a built-in power good (PG) output to indicate whether or not the output voltage is in regulation. The PG signal can be used for startup sequencing of multiple rails. The PG pin is an open-drain output that requires a pull-up resistor to any positive voltage up to 5.5 V. It can sink 1 mA of current and maintain its specified logic low level. PG is low when the device is turned off due to  $EN = \text{low}$ , undervoltage lockout, or thermal shutdown. There is a typical de-glitch time of 10  $\mu\text{s}$  on the power good output. The minimum  $V_{IN}$  to drive the PG pin properly is typically 2 V. If not used, the PG pin may be left floating or connected to GND.

$V_{AUX}$  may be used to pull-up the PG pin, but the pull-up resistor must be chosen such that the maximum load of 100  $\mu\text{A}$  on  $V_{AUX}$  is not exceeded.

During start-up, the power good signal is gated by the soft-start circuit such that the output is held low as long as the soft-start is ongoing.

**表 2. Power Good Pin Logic Table**

EN	device status	PG state
X	$V_{IN} < 2\text{ V}$	high impedance
low	$V_{IN} \geq 2\text{ V}$	low
high	$2\text{ V} \leq V_{IN} < UVLO$ OR in thermal shutdown OR $V_{OUT}$ not in regulation	low
high	$V_{OUT}$ in regulation	high impedance

## 7.4 Device Functional Modes

### 7.4.1 Soft-Start

The discharge circuit keeps the output voltage at 0 V when the TPS63710 is disabled. The TPS63710 only begins the start-up cycle when the output voltage is between +300 mV to -300 mV to ensure a proper start-up. When the output voltage is not in this range, the device keeps the discharge switch on and waits until the voltage is within the window.

When the device is enabled, the internal reference is powered up. After the startup delay time when the  $C_{CP}$  capacitor is pre-charged, the device enters soft-start, starts switching and ramps down the output voltage. Soft-start is achieved by ramping the reference voltage, hence the output voltage, to its nominal value. This ramp time is defined by an external capacitor connected to the CAP pin. The capacitor is charged with typically 100  $\mu\text{A}$  by an internal current source. The ramp time is defined in [公式 2](#).

$$t_{\text{ramp}} = \frac{C_{\text{CAP}} \times V_{\text{REF}}}{I_{\text{ramp}}} = \frac{C_{\text{CAP}} \times 0.9 \times V_{\text{OUT}}}{I_{\text{ramp}}} \quad (2)$$

### 7.4.2 VOUT Discharge

The  $V_{OUT}$  pin has a discharge circuit to connect the output to GND, once the device is disabled. This feature prevents residual voltages on the output capacitor. The discharge circuit becomes active when  $V_{IN}$  drops below  $V_{UVLO}$ ,  $EN = \text{low}$ , or thermal shutdown occurs. The minimum supply voltage required to drive the discharge switch is typically 2 V.

## Device Functional Modes (接下页)

### 7.4.3 Current Limit

A current limit protects the device against short circuits at the output. The current limit is scaled down from its nominal value for input voltages below 4 V. The current limit monitors the peak current in the LSD during the ON-time. If this current is reached during the ON-time, the LSD is turned off and the HSD and RECT turned on to decrease the current. The next ON-time begins at the next switching cycle.

A short circuit from VIN to GND during operation should be avoided as this leads to a high current discharging the  $C_{CP}$  capacitor through the back-gate diode of the high side switch to GND. When there is an overload on the output and the output voltage drops below 0.9 times the target output voltage, the device re-starts.

### 7.4.4 $C_{CP}$ Capacitor Precharge

The  $C_{CP}$  capacitor is pre-charged during the start-up delay phase by a current that increases up to 50 mA based on the voltage of  $V_{IN} - V_{CP}$ . When the voltage on  $C_{CP}$  reaches approximately the  $V_{IN}$  level, the device starts switching.

### 7.4.5 PWM Operation

The converter operates with a fixed-frequency, pulse-width-modulated control. In the OFF-time, the rectifier switch (RECT) and the high-side switch (HSD) are turned on to charge  $C_{CP}$  to the input voltage. As well, the inductor current ramps down, continuing to charge the output capacitor. During the ON-time, the low-side switch (LSD) is closed and HSD and RECT are opened.  $C_{CP}$  inverts the supply voltage onto SW, and the inductor current is ramped up. The LC output filter filters the SW voltage, just like in a step-down converter. Charging the  $C_{CP}$  capacitor during the OFF-time limits the maximum duty cycle. The upper limit of the duty cycle is 70% to allow charging the  $C_{CP}$  capacitor in the remaining 30%.

Lower negative voltages require higher positive supply voltages. For an output voltage of -1.8 V, a minimum input voltage of 4.5 V is sufficient while for an output voltage of -3.3 V, the input voltage has to be above 6 V. See [图 37](#) to [图 39](#) for the relation of input voltage, output voltage and temperature vs output current.

For high input voltages and, in absolute value, small output voltages, the device operates with its minimum on-time ( $t_{on,min}$ ) to generate the duty cycle required for this  $V_{IN}$  and  $V_{OUT}$  ratio. This means that, for such cases, the switching frequency is lower than  $f_S$ .

## 8 Application and Implementation

### 注

Information in the following applications sections is not part of the TI component specification, and TI does not warrant its accuracy or completeness. TI's customers are responsible for determining suitability of components for their purposes. Customers should validate and test their design implementation to confirm system functionality.

### 8.1 Application Information

The TPS63710 is intended for systems typically powered by a pre-regulated power supply but can also run on a battery with a supply voltage range between 3.1 V and 14 V.

### 8.2 Typical Application

The application covers the input voltage range from 4.5 V to 14 V at the full 1-A output current. The output capacitors are designed for an output voltage of -1.8 V. With output voltages below -1.8 V (larger negative voltages), the output capacitance has to be increased as described in the [Detailed Design Procedure](#). The minimum supply voltage is defined by the 70% duty cycle limit, output current and the output voltage. Please see [图 37](#) to [图 39](#) for the recommended input voltage levels to generate a specific output voltage.

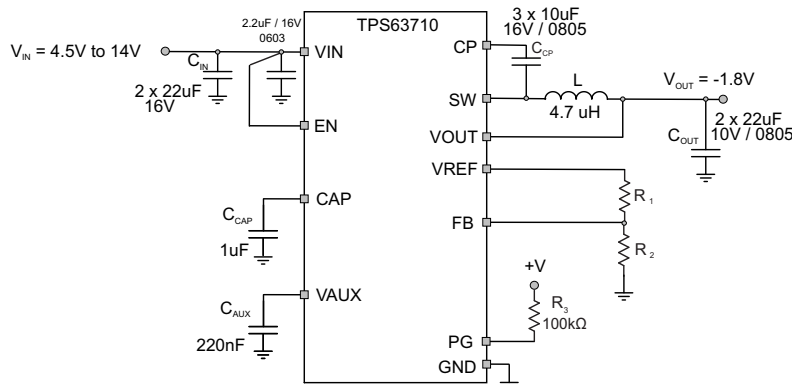

Copyright © 2017, Texas Instruments Incorporated

图 10. Typical Application for an Input Voltage up to 14V

#### 8.2.1 Design Requirements

The design of the inverter can be adapted to different output voltages and load currents. The following components cover an input voltage range up to 9 V. For  $C_{IN}$ , a 0603 capacitor close to the device pins is required in addition to the larger capacitor. As the  $C_{CP}$  capacitor has the same voltage across it, its dc bias effect is similar to  $C_{IN}$ . [表 3](#) gives examples for the schematics optimized for different input and output voltage ranges.

表 3. Bill of Materials

Reference	Part Number	Value	Manufacturer <sup>(1)</sup>
IC	TPS63710DRR		Texas Instruments
$C_{IN}$	EMK107BB7225KA-T EMK316BB7226ML-T	2.2 µF / 16 V + 2 x 22 µF / 16 V	Taiyo Yuden
$C_{CP}$	EMK212BB7106MG-T	3 x 10 µF / 16V	Taiyo Yuden
$C_{OUT}$	C2012X7S1A226M125AC	2 x 22 µF / 10 V	TDK
L	XFL4020-222	2.2 µH	Coilcraft
$C_{CAP}$	885012206026	1 µF / 10 V	Würth
$C_{AUX}$	885012206022	220 nF / 10 V	Würth
$R_1$		196 kΩ	

(1) See [Third-party Products Disclaimer](#)

## Typical Application (接下页)

表 3. Bill of Materials (接下页)

Reference	Part Number	Value	Manufacturer <sup>(1)</sup>
R <sub>2</sub>		150 kΩ	
R <sub>3</sub>		100 kΩ	

### 8.2.2 Detailed Design Procedure

#### 8.2.2.1 Custom Design With WEBENCH® Tools

[Click here](#) to create a custom design using the TPS63710 device with the WEBENCH® Power Designer.

1. Start by entering the input voltage ( $V_{IN}$ ), output voltage ( $V_{OUT}$ ), and output current ( $I_{OUT}$ ) requirements.
2. Optimize the design for key parameters such as efficiency, footprint, and cost using the optimizer dial.
3. Compare the generated design with other possible solutions from Texas Instruments.

The WEBENCH Power Designer provides a customized schematic along with a list of materials with real-time pricing and component availability.

In most cases, these actions are available:

- Run electrical simulations to see important waveforms and circuit performance
- Run thermal simulations to understand board thermal performance
- Export customized schematic and layout into popular CAD formats
- Print PDF reports for the design, and share the design with colleagues

Get more information about WEBENCH tools at [www.ti.com/WEBENCH](http://www.ti.com/WEBENCH).

#### 8.2.2.2 Setting the Output Voltage

The output voltage of the TPS63710 converter is adjusted with an external resistor divider connected to the FB pin. The voltage at the feedback pin is negative and is regulated to -0.7 V. The gain stage adds a gain factor of 1/0.9 such that the output voltage is -0.778 V for -0.7 V of FB voltage. See [Low Noise Reference System](#) for details.

The value of the output voltage is set by the selection of the resistive divider using [公式 3](#) and  $V_{FB\_SET} = -0.778$  V. Both  $V_{OUT}$  and  $V_{FB\_SET}$  are negative, so the ratio is positive again.

$$R_1 = R_2 \times \left( \frac{V_{OUT}}{V_{FB\_SET}} - 1 \right) \quad (3)$$

It is recommended to choose resistor values such that  $R_1 + R_2$  are in a range from 100 kΩ to 500 kΩ. For example, if an output voltage of -1.8 V is needed and a resistor of 150-kΩ has been chosen for  $R_2$ , a 196-kΩ resistor on  $R_1$  is required to program the desired output voltage.

表 4. Recommended Resistor Values

Output Voltage	R <sub>1</sub>	R <sub>2</sub>
-1 V	51.1 kΩ	180 kΩ
-1.8 V	196 kΩ	150 kΩ
-2.5 V	287 kΩ	130 kΩ
-5 V	130 kΩ	24 kΩ

For proper regulation, the minimum input voltage should remain at least above the output voltage, per [公式 4](#):

$$V_{IN} \geq \frac{1}{0.7} \times |V_{OUT}| \quad (4)$$

See [图 37](#) to [图 39](#) for the recommended input voltage levels to generate a specific output voltage.

### 8.2.2.3 Inductor Selection

The basic parameters for choosing an appropriate inductor is saturation current, as well as the dc resistance of the inductor. The TPS63710 is designed such that it operates with an inductance as given in the recommended operating conditions. For best performance, a nominal inductance of 2.2 μH should be used for input voltages below 9 V. For input voltages above 9 V, a nominal inductance of 4.7 μH is preferred to keep the inductor current ripple at a reasonable level.

Similar to a step-down converter, the inductor along with the output capacitor forms a LC filter. For noise-sensitive applications, larger values for the inductance and output capacitance are preferred to get the noise level at the output to very low values.

The peak inductor current depends on the output load, the input voltage  $V_{IN}$ , and the output voltage  $V_{OUT}$ . The average inductor current equals the load current.

The topology can be simplified to an inverter stage followed by a step-down converter. The equations for calculating the inductor current of a step-down converter therefore also apply. The worst case inductor ripple current occurs at 50% duty cycle which is when  $V_{IN} = 2 \times |V_{OUT}|$ . The voltage across the inductor is  $V_{IN} - |V_{OUT}|$ , which is  $0.5 \times V_{IN}$  at 50% duty cycle. With this, 公式 5 and  $dt = 0.5 \times 1/f_s$ , the peak to peak inductor ripple current is defined by 公式 6. The inductor’s saturation current must remain above its peak current which is calculated in 公式 7. 表 5 shows a list of recommended inductors.

$$V = L \times \frac{dI}{dt} \tag{5}$$

$$\Delta I_{pp} = \frac{V_{IN} \times 0.5}{L} \times \frac{1}{f_s} \times 0.5 = \frac{|V_{OUT}|}{L} \times \frac{1}{f_s} \times 0.5 \tag{6}$$

$$I_{L_{peak}} = I_{OUT} + \frac{1}{2} \Delta I_{pp} \tag{7}$$

表 5. List of Inductors

Input Voltage	Vendor	comment	Suggested Inductor <sup>(1)</sup>
3.1 V to 9 V	Coilcraft		XFL3012-222ME
3.1 V to 9 V	Coilcraft	best performance for low input voltage	XFL4020-222ME
3.1 V to 9 V	Toko	low cost; small size	DFE252012F-2R2M
3.1 V to 14 V	Coilcraft		XFL4020-472ME
3.1 V to 14 V	Würth		744 383 570 47

(1) See [Third-party Products Disclaimer](#)

### 8.2.2.4 Capacitor Selection

#### 8.2.2.4.1 C<sub>CP</sub> Capacitor

The capacitance of C<sub>CP</sub> determines the maximum output current of TPS63710. Therefore it is selected at first. A minimum 4-μF of effective capacitance is required to support the full output current of 1 A. Only ceramic capacitors like X7R, X5R or equivalent are recommended. For applications that require a lower maximum output current, its value can be reduced linearly. As the voltage at the C<sub>CP</sub> capacitor is equal to the input voltage  $V_{IN}$ , the dc bias effect has to be taken into account based on the maximum input voltage. 表 6 shows recommended C<sub>CP</sub> capacitors.

表 6. C<sub>CP</sub> Capacitor Selection

input voltage range; $V_{IN}$	nominal value	voltage rating	package size	number of capacitors required for 1A of output current based on dc bias effect	Suggested Capacitors <sup>(1)</sup>
3.1 V to 6 V	10 μF	> $V_{IN}$	0805	2	EMK212BB7106MG-T
3.1 V to 14 V	10 μF	> $V_{IN}$	0805	3	EMK212BB7106MG-T

(1) See [Third-party Products Disclaimer](#)

### 8.2.2.4.2 Input Capacitor

The capacitance of the input capacitor should be at least twice the capacitance of  $C_{CP}$ . At least a 22- $\mu$ F ceramic input capacitor is recommended for a good transient behavior of the regulator and EMI behavior of the total power supply circuit. The capacitor must be located as close to the VIN and GND pins as possible. Only ceramic capacitors like X7R, X5R or equivalent are recommended. A 0603 size 2.2- $\mu$ F ceramic capacitor in parallel to the main input capacitor is recommended to reduce high frequency noise. The input capacitance can be increased without limit. 表 7 shows recommended capacitors.

**表 7. Input Capacitor Selection**

input voltage range; $V_{IN}$	nominal value	voltage rating	package size	number of capacitors required for 1A of output current based on dc bias effect	Suggested Capacitors <sup>(1)</sup>
3.1 V to 6 V	2 x capacitance of $C_{CP}$	$> V_{IN}$	1206	2	EMK316BB7226ML-T
3.1 V to 14 V	2 x capacitance of $C_{CP}$	$> V_{IN}$	1206	3	EMK316BB7226ML-T

(1) See [Third-party Products Disclaimer](#)

### 8.2.2.4.3 Output Capacitor

One of the major parameters necessary to define the capacitance value of the output capacitor is the maximum allowed output voltage ripple of the converter and device stability. Internal device compensation defines the limits for the capacitance on the output. Only ceramic capacitors like X7R, X5R or equivalent are recommended. Table 表 8 gives the minimum amount of capacitors required for a given output voltage based on the dc bias effect. For lowest output voltage ripple, more capacitance can be added up to the maximum value as defined in the recommended operating conditions.

**表 8. Output Capacitor Selection**

output voltage range; $V_{OUT}$	nominal value	voltage rating	package size	number of capacitors required based on dc bias effect	Suggested Capacitors <sup>(1)</sup>
-1 V to -3.3 V	22 $\mu$ F	$\geq 6.3$ V	0805	2	C2012X7S1A226M125AC
-1 V to -5.5 V	22 $\mu$ F	$\geq 10$ V	0805	3	C2012X7S1A226M125AC

(1) See [Third-party Products Disclaimer](#)

### 8.2.3 Application Curves

#### 8.2.3.1 Parameter Measurement Information

The application curves have been taken using the schematic in 图 10 and BOM according 表 3. Based on the output voltage, the components given in 表 9 have been changed. The resistor divider is based on 表 4.

表 9. Component Selection for  $V_{OUT}$  Options

$V_{OUT}$	$C_{CP}$	L	$C_{OUT}$
-1 V and -1.8 V	2 x EMK212BB7106MG-T	XFL4020-222ME	2 x C2012X7S1A226M125AC
-3.3 V and -5 V	3 x EMK212BB7106MG-T	XFL4020-472ME	3 x C2012X7S1A226M125AC

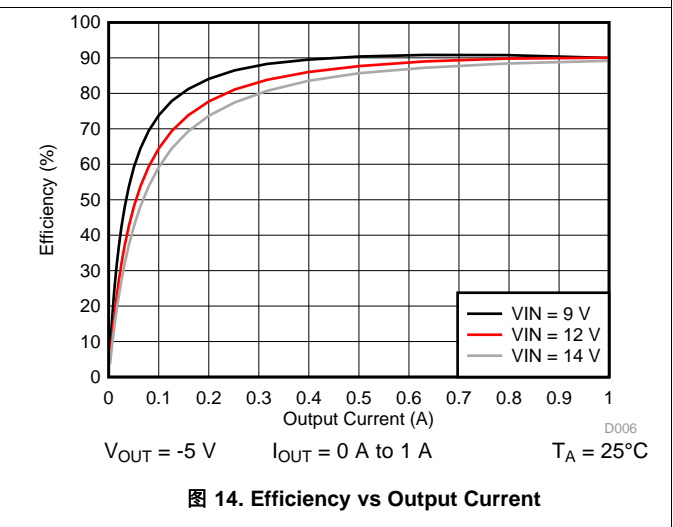
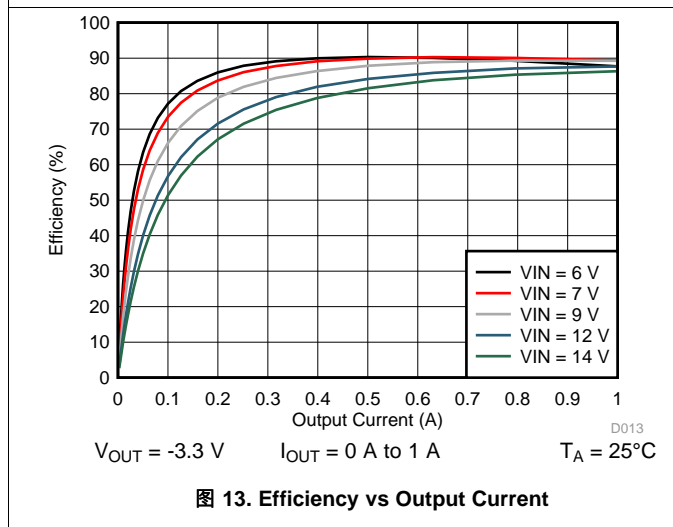
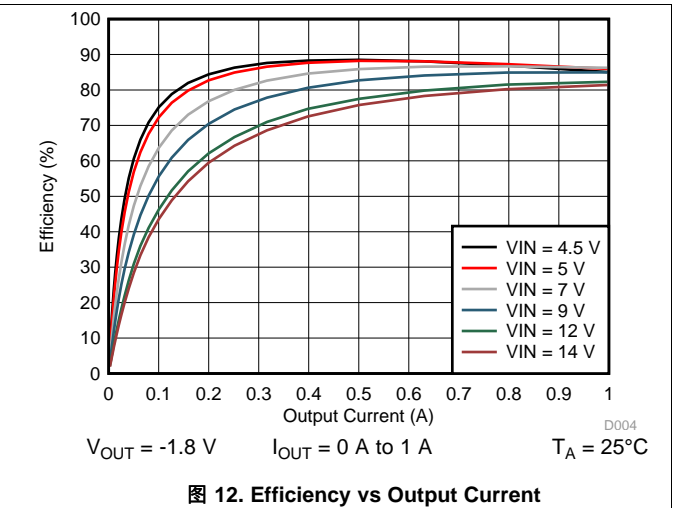
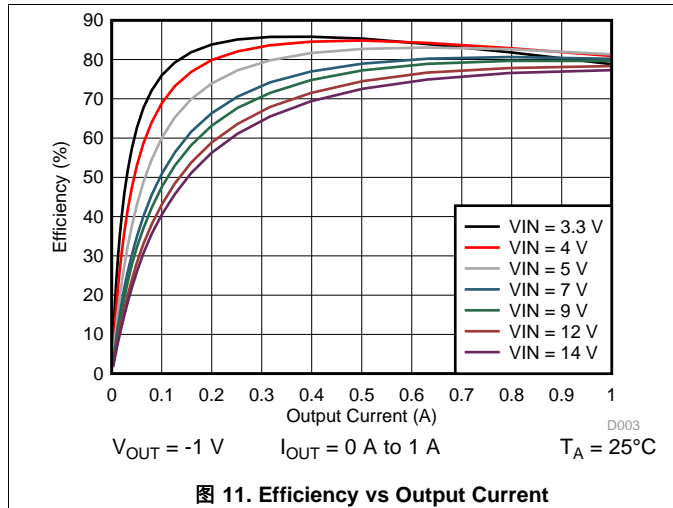

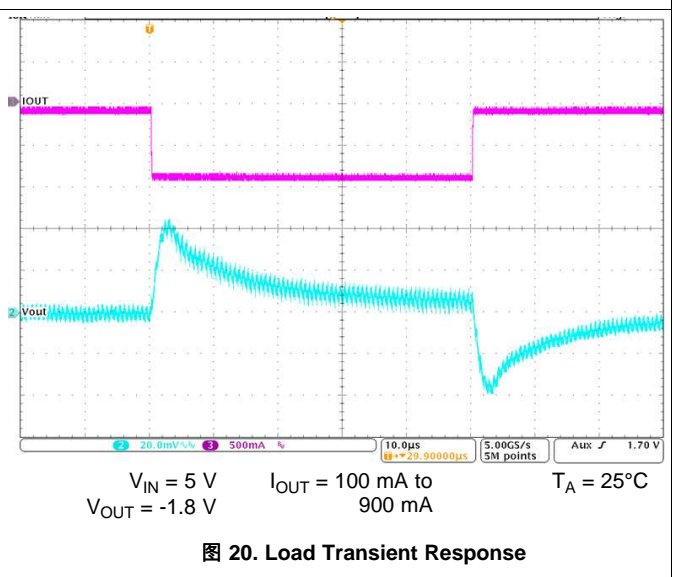
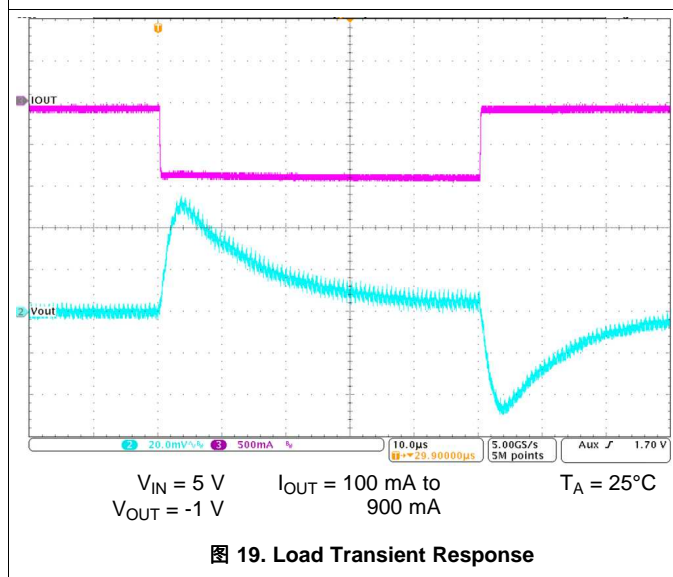
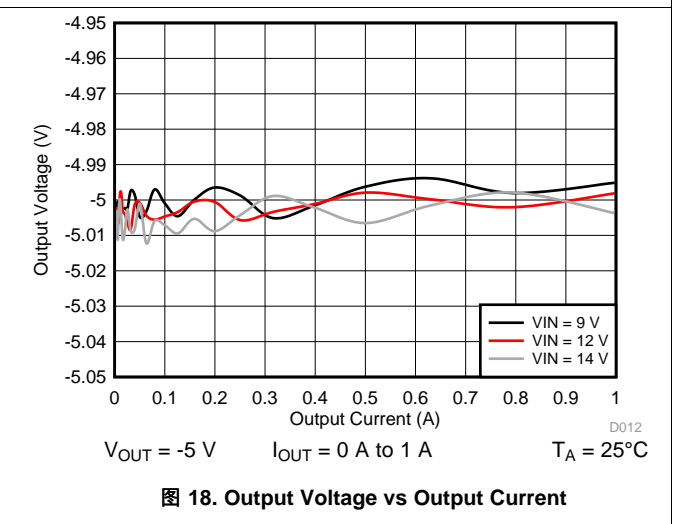
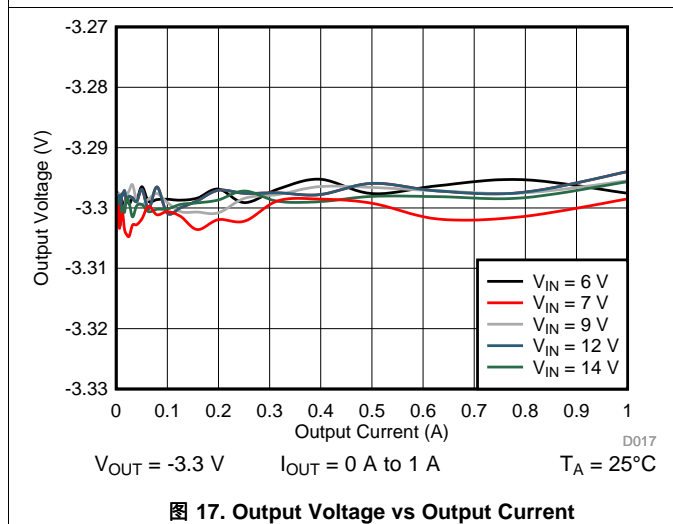
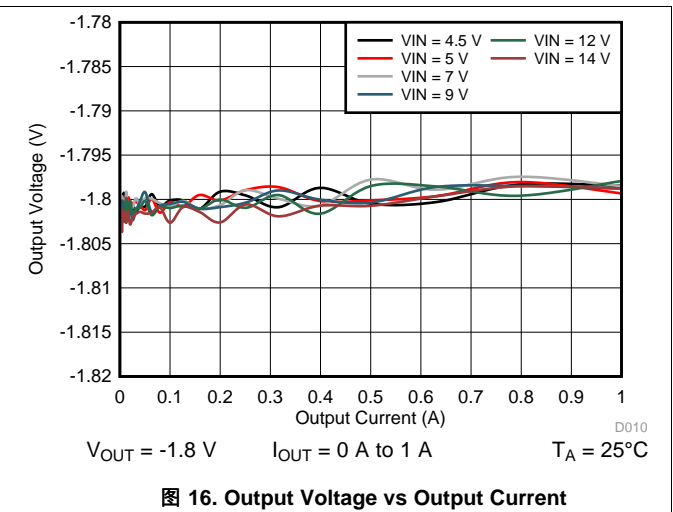
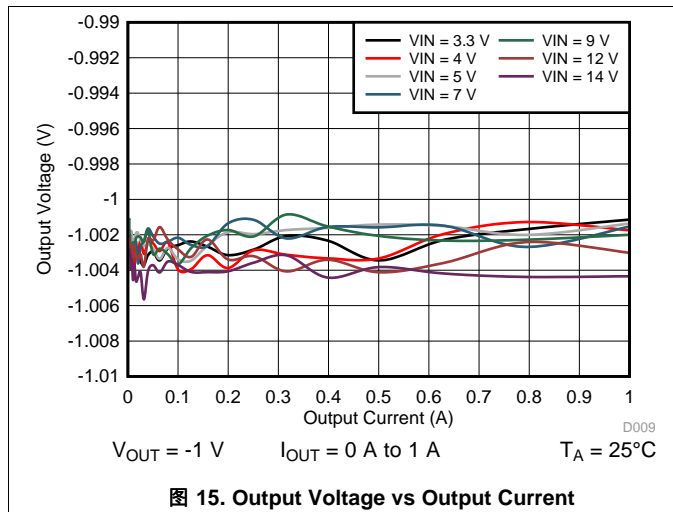



图 21. Load Transient Response



图 22. Load Transient Response

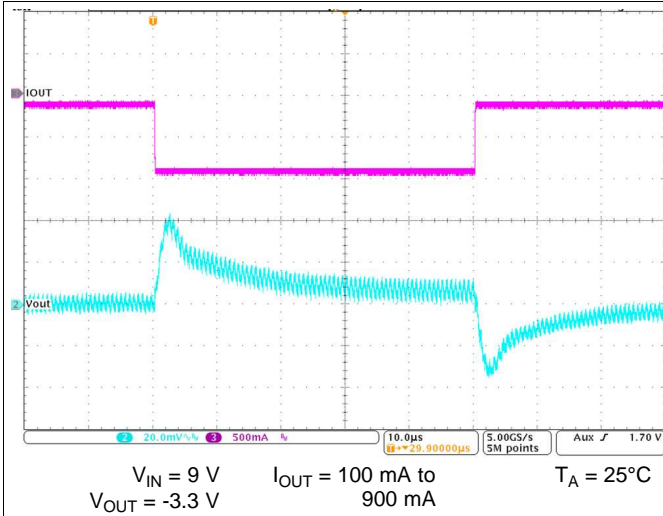

图 23. Line Transient Response

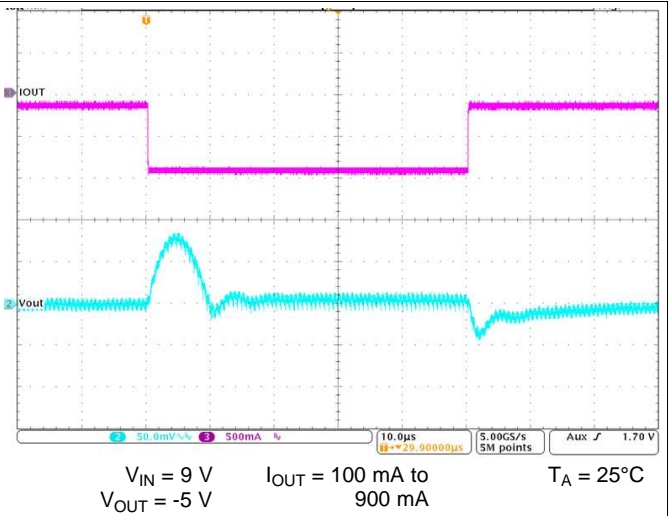

图 24. Line Transient Response

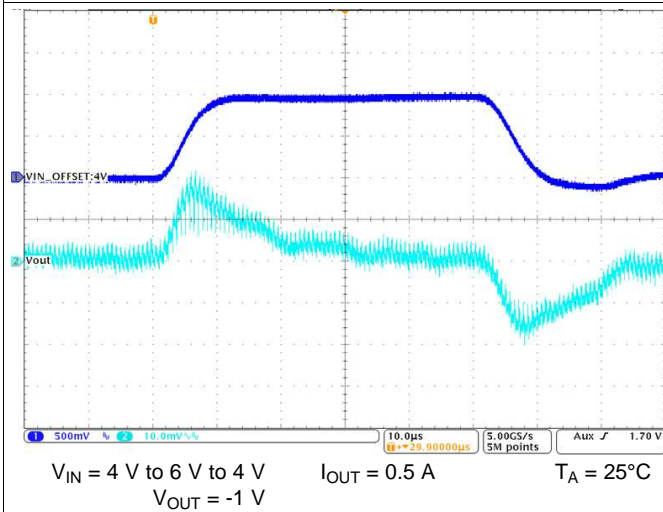

图 25. Line Transient Response

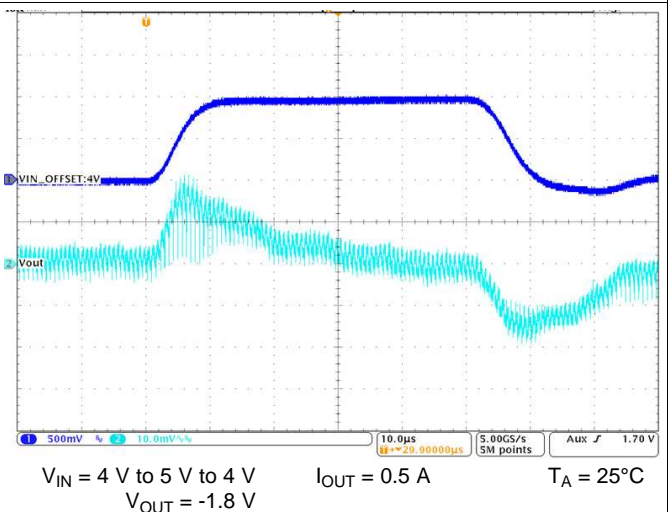

图 26. Line Transient Response

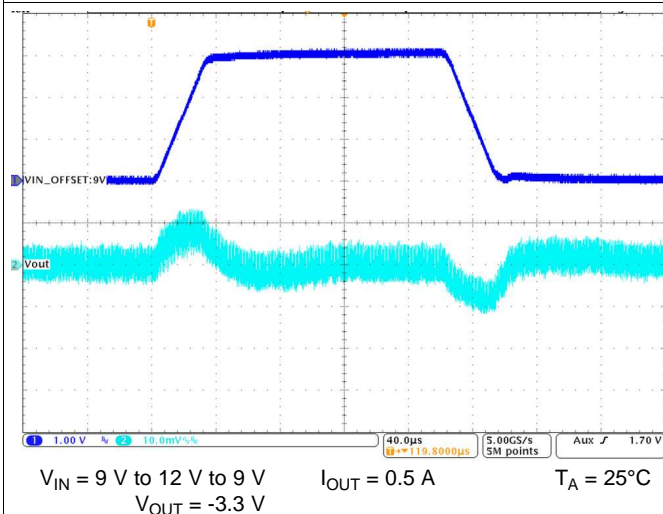

图 27. Start-Up Timing

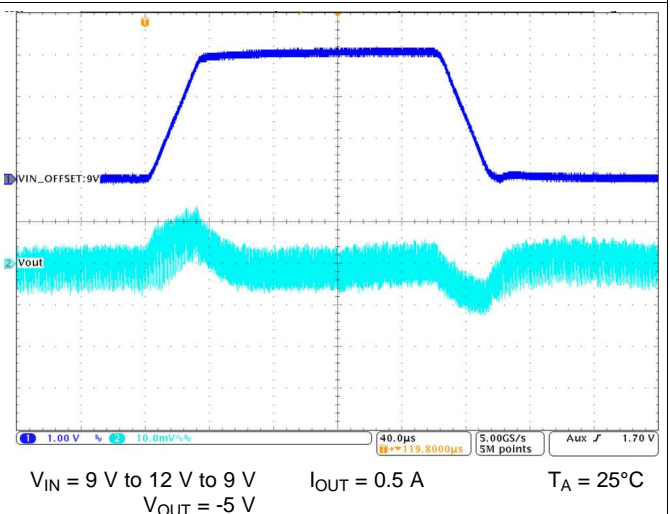

图 28. Start-Up Timing

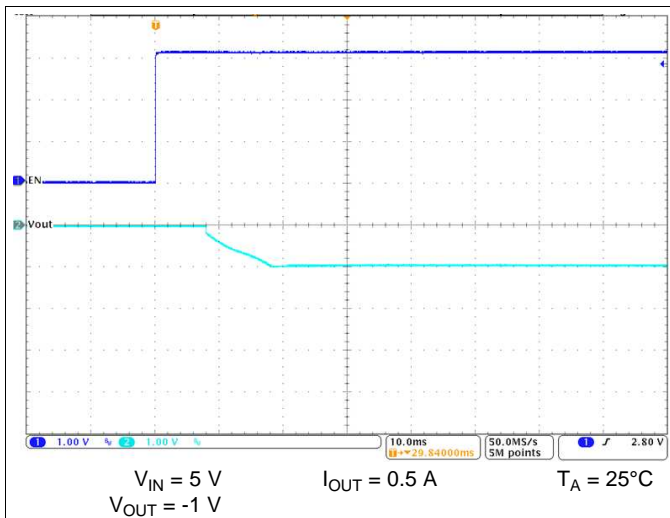

图 29. Start-Up Timing

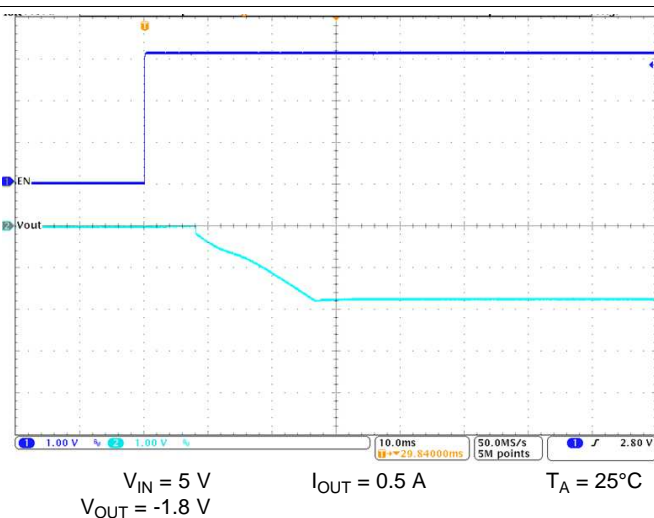

图 30. Start-Up Timing

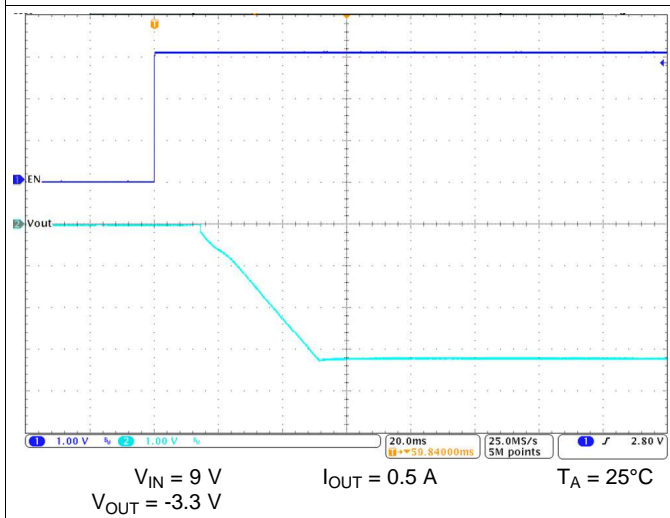

图 31. Output Voltage Ripple

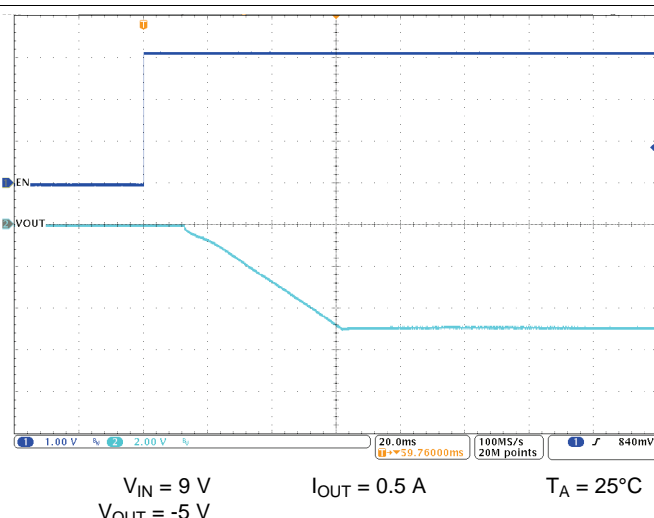

图 32. Output Voltage Ripple

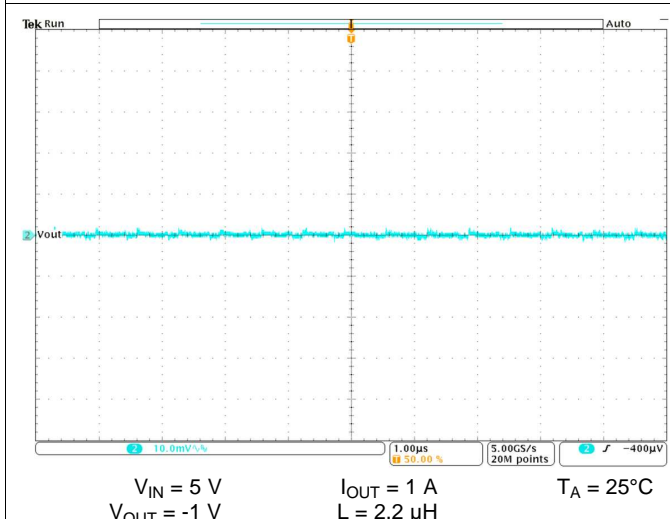

图 33. Output Voltage Ripple

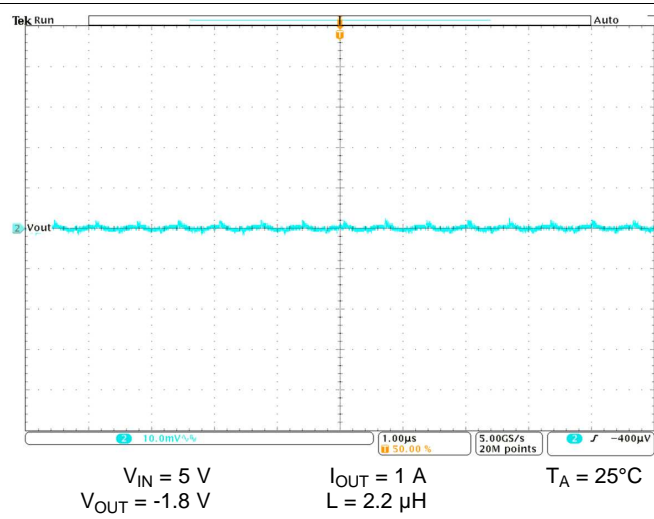

图 34. Output Voltage Ripple

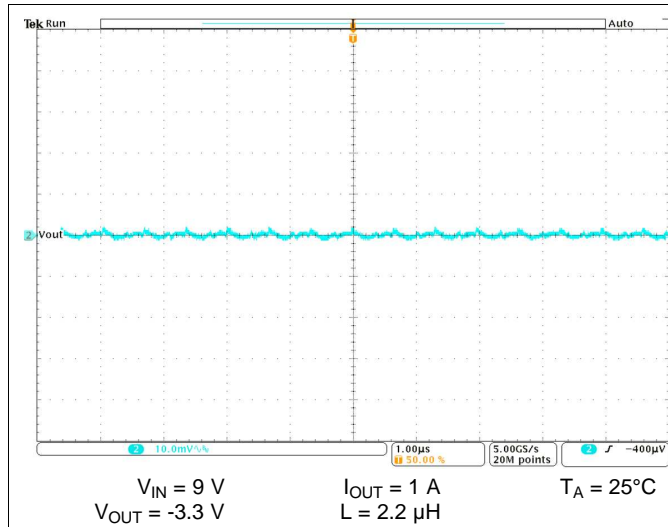

图 35. Output Voltage Ripple

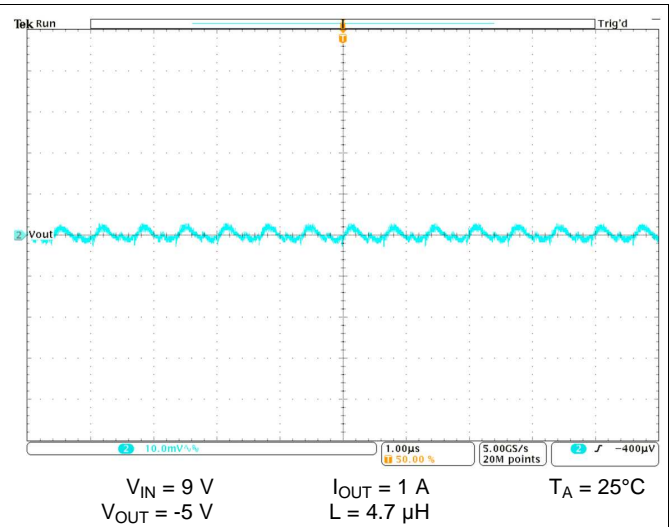

图 36. Output Voltage Ripple

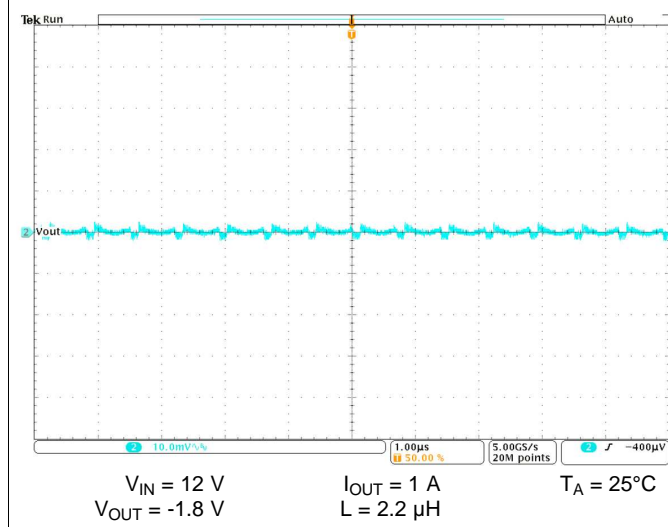

图 37. Maximum Output Current vs Input Voltage

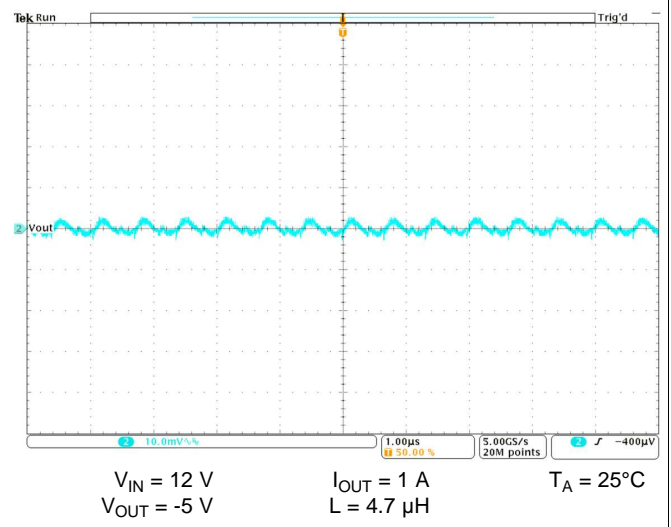

图 38. Maximum Output Current vs Input Voltage

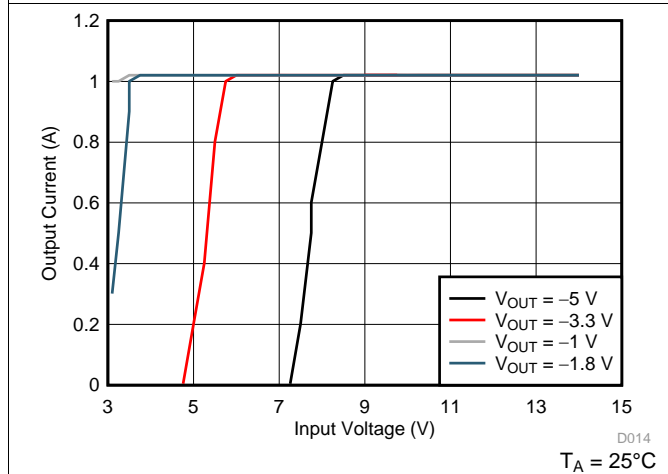

图 39. Maximum Output Current vs Input Voltage

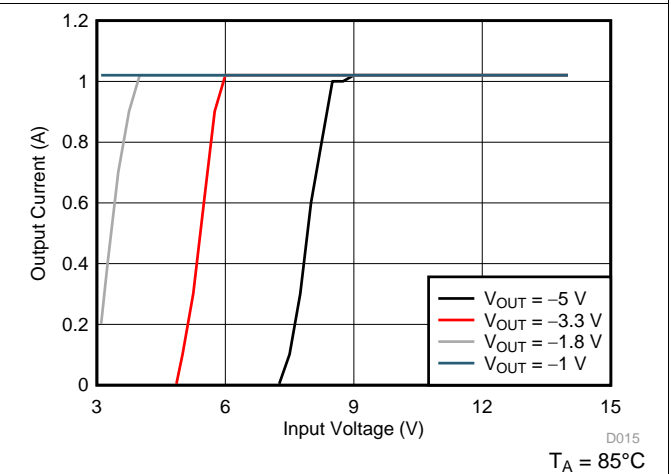

图 40. Output Noise Density

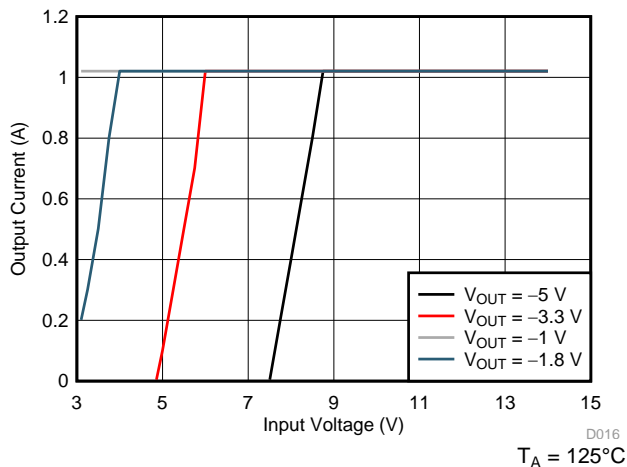

图 41. Output Noise Density

## 8.3 System Examples

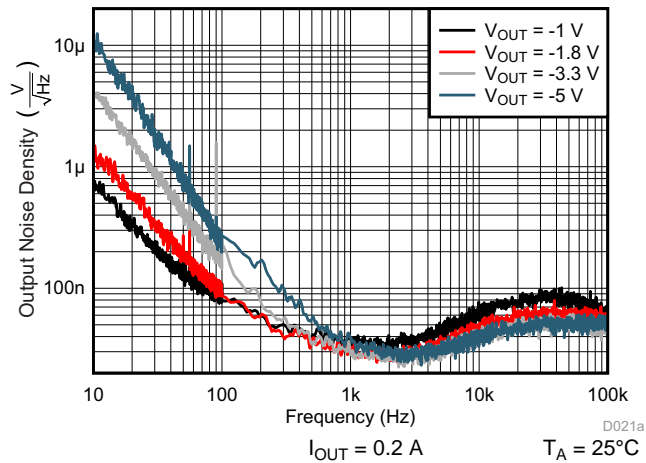
### 8.3.1 Typical Application for Powering the Negative Rail of a Gallium Nitride (GaN) Power Amplifier

The TPS63710 requires a supply voltage in the range of 8.8 V to 14 V in order to generate an output voltage of -5 V. The circuit therefore was optimized for this input voltage range. The number of the input, output and  $C_{CP}$  capacitors have been adjusted to compensate for the higher dc bias effect with large input and output voltages. In addition, the inductor has been changed to 4.7  $\mu\text{H}$  for low inductor current ripple at an input voltage up to 14 V.

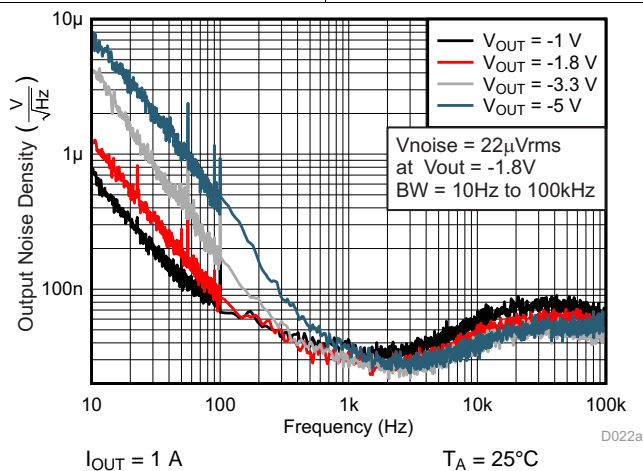
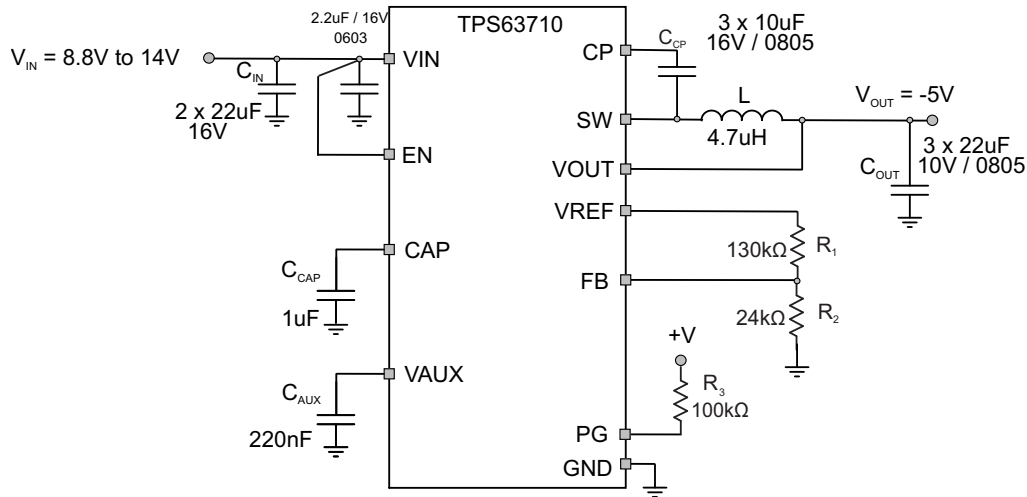

Copyright © 2017, Texas Instruments Incorporated

图 42. Typical Application for an Output Voltage of -5 V

### 8.3.2 Typical Application for Powering the Negative Rail of an ADC or DAC

Typically, the input voltage to the inverter in applications powering the negative supply of an ADC or DAC is about 5 V. The circuit therefore was optimized for this input voltage range, because the size and amount of capacitors depends on the voltage applied to the capacitors. In order not to over-design, the input voltage range was set to the range required to set a limit for the dc bias of the capacitors. 图 43 shows a, for an input voltage of 5-V, optimized design. The minimum input voltage to support the full output current is 4.5 V. The maximum input voltage is defined by the dc bias characteristic of the input and  $C_{CP}$  capacitors. If a higher input voltage is required, these capacitors have to be adjusted accordingly.

System Examples (接下页)

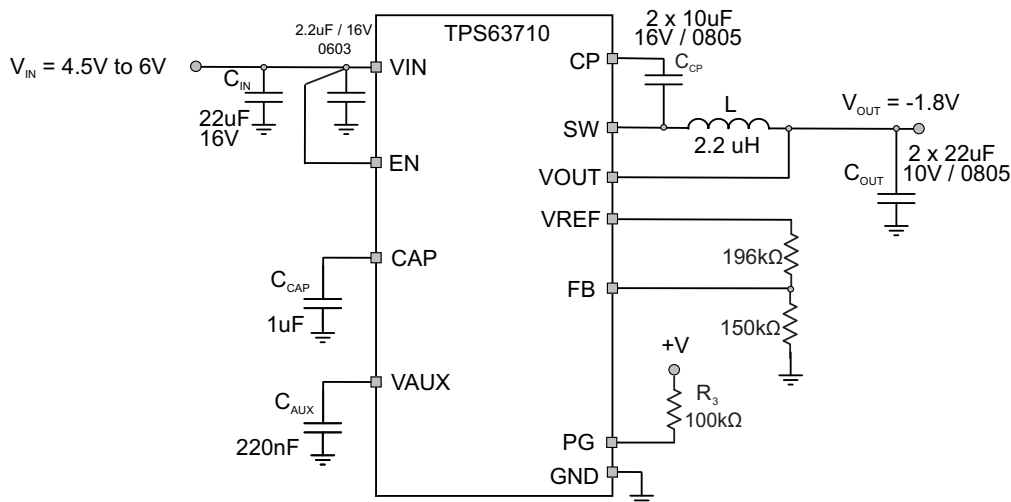

Copyright © 2017, Texas Instruments Incorporated

图 43. Typical Application for  $V_{IN} \approx 5\text{ V}$

8.3.3 Typical Application for Laser Diode Bias

Laser diode bias typically requires a voltage of about -1 V from a 3.3 V supply. The TPS63710 was optimized for these operating conditions. The passive components have been chosen for a fixed supply voltage of 3.3 V. The number of the input, output and  $C_{CP}$  capacitors have been adjusted for the input and output voltage in this application.

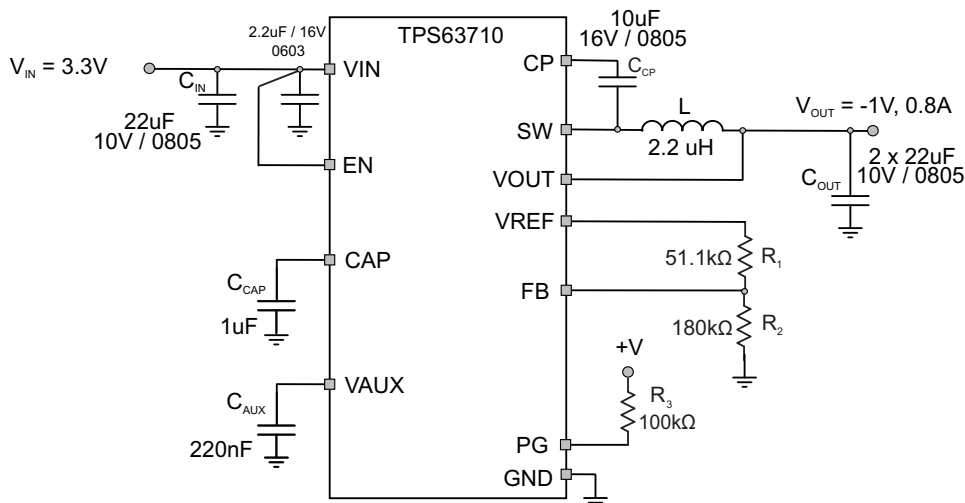

Copyright © 2017, Texas Instruments Incorporated

图 44. Typical Application for an Output Voltage of -1 V

## 9 Power Supply Recommendations

The power supply to the TPS63710 needs to have a current rating according to the input supply voltage, output voltage and output current of the TPS63710. The peak current requirement on the input depends on the duty cycle, as  $C_{CP}$  is charged during the off-time. Worst case is for the maximum duty cycle of 70% when the OFF-time is at its shortest value of 30%. The peak current on the input can be up to 5 times of the average output current. A proper input capacitor needs to be placed directly at the VIN and GND pins to supply the peak current demand of the converter. Slew rates faster than 1 V/ $\mu$ s for a  $V_{IN}$  step of less than 1 V and 0.1 V/ $\mu$ s for a  $V_{IN}$  step over the full input voltage range up to 14 V should be avoided, as this leads to a large inrush current through the  $C_{CP}$  capacitor and HSD.

When the input supply of TPS63710 is shorted while the device is enabled, the charge stored on the  $C_{CP}$  capacitor is transferred to the output. This may cause an output voltage undershoot. It is recommended to disable the TPS63710 by setting the EN pin to low while the supply voltage is within the recommended input voltage range. This ensures a proper shutdown.

## 10 Layout

### 10.1 Layout Guidelines

For all switching power supplies, the layout is an important step in the design, especially at high peak currents and high switching frequencies. If the layout is not carefully done, the regulator could show stability problems as well as EMI problems. Therefore, use wide and short traces for the main current paths, and for the power-ground tracks. The input, output and CP capacitors should be placed as close as possible to the IC. Because  $C_{VAUX}$  carries the peak currents of the gate control block, it should have a compact and direct routing to the VAUX and GND pin 10, staying away from sensitive signals. The CAP, FB, and VREF pins should all be routed close to the IC in order to keep them away from external noise. The total resistance of the voltage divider  $R_1 + R_2$  must be kept in the range as defined in the Recommended Operating Conditions.

The pinout of the device has been defined such that the external components can be placed directly at the pins to allow for a simplified external layout and good performance. Thermal and electrical vias should be used under the exposed thermal pad to the GND plane.

### 10.2 Layout Example



图 45. Recommended Layout

## 11 器件和文档支持

### 11.1 器件支持

#### 11.1.1 使用 WEBENCH® 工具创建定制设计

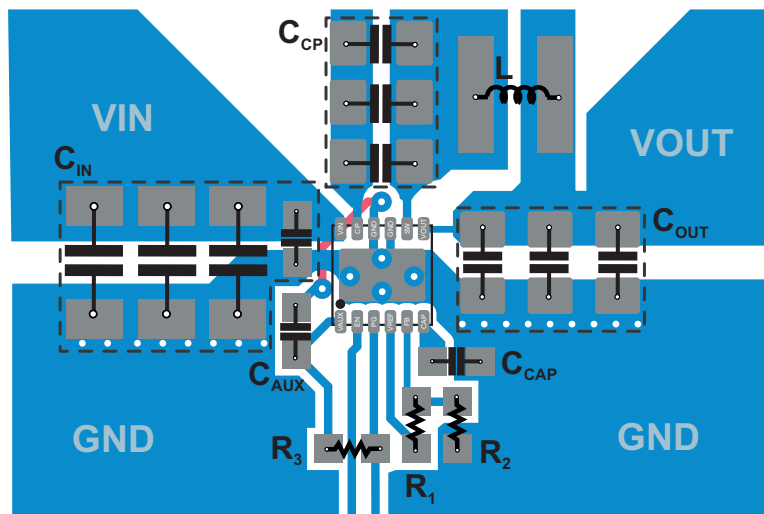
[单击此处](#)，使用 TPS63710 器件并借助 WEBENCH® 电源设计器创建定制设计方案。

1. 首先输入输入电压 ( $V_{IN}$ )、输出电压 ( $V_{OUT}$ ) 和输出电流 ( $I_{OUT}$ ) 要求。
2. 使用优化器拨盘优化该设计的关键参数，如效率、尺寸和成本。
3. 将生成的设计与德州仪器 (TI) 的其他可行的解决方案进行比较。

WEBENCH 电源设计器可提供定制原理图以及罗列实时价格和组件供货情况的物料清单。

在多数情况下，可执行以下操作：

- 运行电气仿真，观察重要波形以及电路性能
- 运行热性能仿真，了解电路板热性能
- 将定制原理图和布局方案以常用 CAD 格式导出
- 打印设计方案的 PDF 报告并与同事共享

有关 WEBENCH 工具的详细信息，请访问 [www.ti.com.cn/WEBENCH](http://www.ti.com.cn/WEBENCH)。

#### 11.1.2 第三方产品免责声明

TI 发布的与第三方产品或服务有关的信息，不能构成与此类产品或服务或保修的适用性有关的认可，不能构成此类产品或服务单独或与任何 TI 产品或服务一起的表示或认可。

### 11.2 社区资源

下列链接提供到 TI 社区资源的连接。链接的内容由各个分销商“按照原样”提供。这些内容并不构成 TI 技术规范，并且不一定反映 TI 的观点；请参阅 TI 的《使用条款》。

**TI E2E™ 在线社区** [TI 的工程师对工程师 \(E2E\) 社区](#)。此社区的创建目的在于促进工程师之间的协作。在 [e2e.ti.com](http://e2e.ti.com) 中，您可以咨询问题、分享知识、拓展思路并与同行工程师一道帮助解决问题。

**设计支持** [TI 参考设计支持](#) 可帮助您快速查找有帮助的 E2E 论坛、设计支持工具以及技术支持的联系信息。

### 11.3 商标

E2E is a trademark of Texas Instruments.

WEBENCH is a registered trademark of Texas Instruments.

All other trademarks are the property of their respective owners.

### 11.4 静电放电警告



这些装置包含有限的内置 ESD 保护。存储或装卸时，应将导线一起截短或将装置放置于导电泡棉中，以防止 MOS 门极遭受静电损伤。

### 11.5 术语表

[SLYZ022](#) — TI 术语表。

这份术语表列出并解释术语、缩写和定义。

## 12 机械、封装和可订购信息

以下页面包含机械、封装和可订购信息。这些信息是指定器件的最新可用数据。数据如有变更，恕不另行通知，且不会对此文档进行修订。如欲获取此产品说明书的浏览器版本，请参阅左侧的导航。

**PACKAGING INFORMATION**

Orderable Device	Status (1)	Package Type	Package Drawing	Pins	Package Qty	Eco Plan (2)	Lead finish/ Ball material (6)	MSL Peak Temp (3)	Op Temp (°C)	Device Marking (4/5)	Samples
TPS63710DRRR	ACTIVE	WSON	DRR	12	3000	RoHS & Green	NIPDAU	Level-2-260C-1 YEAR	-40 to 125	63710	<a href="#">Samples</a>
TPS63710DRRT	ACTIVE	WSON	DRR	12	250	RoHS & Green	NIPDAU	Level-2-260C-1 YEAR	-40 to 125	63710	<a href="#">Samples</a>

(1) The marketing status values are defined as follows:

**ACTIVE:** Product device recommended for new designs.

**LIFEBUY:** TI has announced that the device will be discontinued, and a lifetime-buy period is in effect.

**NRND:** Not recommended for new designs. Device is in production to support existing customers, but TI does not recommend using this part in a new design.

**PREVIEW:** Device has been announced but is not in production. Samples may or may not be available.

**OBSOLETE:** TI has discontinued the production of the device.

(2) **RoHS:** TI defines "RoHS" to mean semiconductor products that are compliant with the current EU RoHS requirements for all 10 RoHS substances, including the requirement that RoHS substance do not exceed 0.1% by weight in homogeneous materials. Where designed to be soldered at high temperatures, "RoHS" products are suitable for use in specified lead-free processes. TI may reference these types of products as "Pb-Free".

**RoHS Exempt:** TI defines "RoHS Exempt" to mean products that contain lead but are compliant with EU RoHS pursuant to a specific EU RoHS exemption.

**Green:** TI defines "Green" to mean the content of Chlorine (Cl) and Bromine (Br) based flame retardants meet JS709B low halogen requirements of <=1000ppm threshold. Antimony trioxide based flame retardants must also meet the <=1000ppm threshold requirement.

(3) MSL, Peak Temp. - The Moisture Sensitivity Level rating according to the JEDEC industry standard classifications, and peak solder temperature.

(4) There may be additional marking, which relates to the logo, the lot trace code information, or the environmental category on the device.

(5) Multiple Device Markings will be inside parentheses. Only one Device Marking contained in parentheses and separated by a "~" will appear on a device. If a line is indented then it is a continuation of the previous line and the two combined represent the entire Device Marking for that device.

(6) Lead finish/Ball material - Orderable Devices may have multiple material finish options. Finish options are separated by a vertical ruled line. Lead finish/Ball material values may wrap to two lines if the finish value exceeds the maximum column width.

**Important Information and Disclaimer:**The information provided on this page represents TI's knowledge and belief as of the date that it is provided. TI bases its knowledge and belief on information provided by third parties, and makes no representation or warranty as to the accuracy of such information. Efforts are underway to better integrate information from third parties. TI has taken and continues to take reasonable steps to provide representative and accurate information but may not have conducted destructive testing or chemical analysis on incoming materials and chemicals. TI and TI suppliers consider certain information to be proprietary, and thus CAS numbers and other limited information may not be available for release.

In no event shall TI's liability arising out of such information exceed the total purchase price of the TI part(s) at issue in this document sold by TI to Customer on an annual basis.

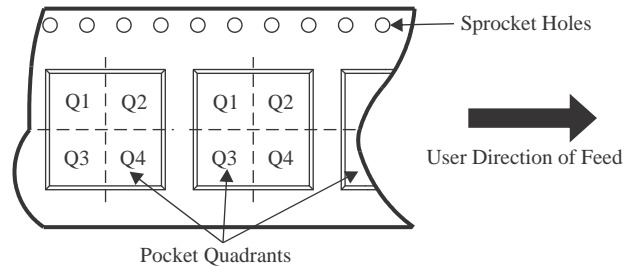

**TAPE AND REEL INFORMATION**

**QUADRANT ASSIGNMENTS FOR PIN 1 ORIENTATION IN TAPE**

\*All dimensions are nominal

Device	Package Type	Package Drawing	Pins	SPQ	Reel Diameter (mm)	Reel Width W1 (mm)	A0 (mm)	B0 (mm)	K0 (mm)	P1 (mm)	W (mm)	Pin1 Quadrant
TPS63710DRRR	WSON	DRR	12	3000	330.0	12.4	3.3	3.3	1.1	8.0	12.0	Q2
TPS63710DRRT	WSON	DRR	12	250	180.0	12.4	3.3	3.3	1.1	8.0	12.0	Q2

**TAPE AND REEL BOX DIMENSIONS**

\*All dimensions are nominal

Device	Package Type	Package Drawing	Pins	SPQ	Length (mm)	Width (mm)	Height (mm)
TPS63710DRRR	WSON	DRR	12	3000	367.0	367.0	35.0
TPS63710DRRT	WSON	DRR	12	250	210.0	185.0	35.0

## GENERIC PACKAGE VIEW

DRR 12

**WSO<sub>N</sub> - 0.8 mm max height**

PLASTIC SMALL OUTLINE - NO LEAD

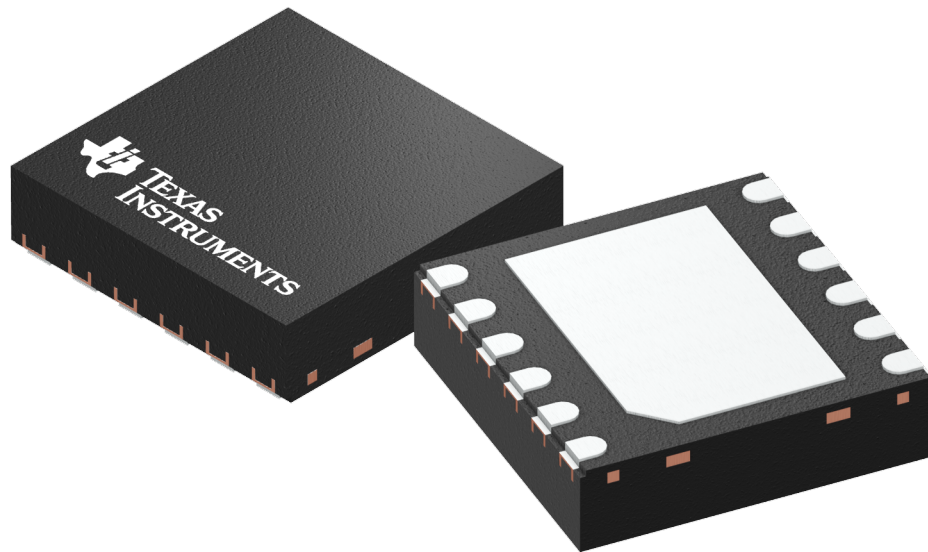

Images above are just a representation of the package family, actual package may vary.  
Refer to the product data sheet for package details.

4223490/A

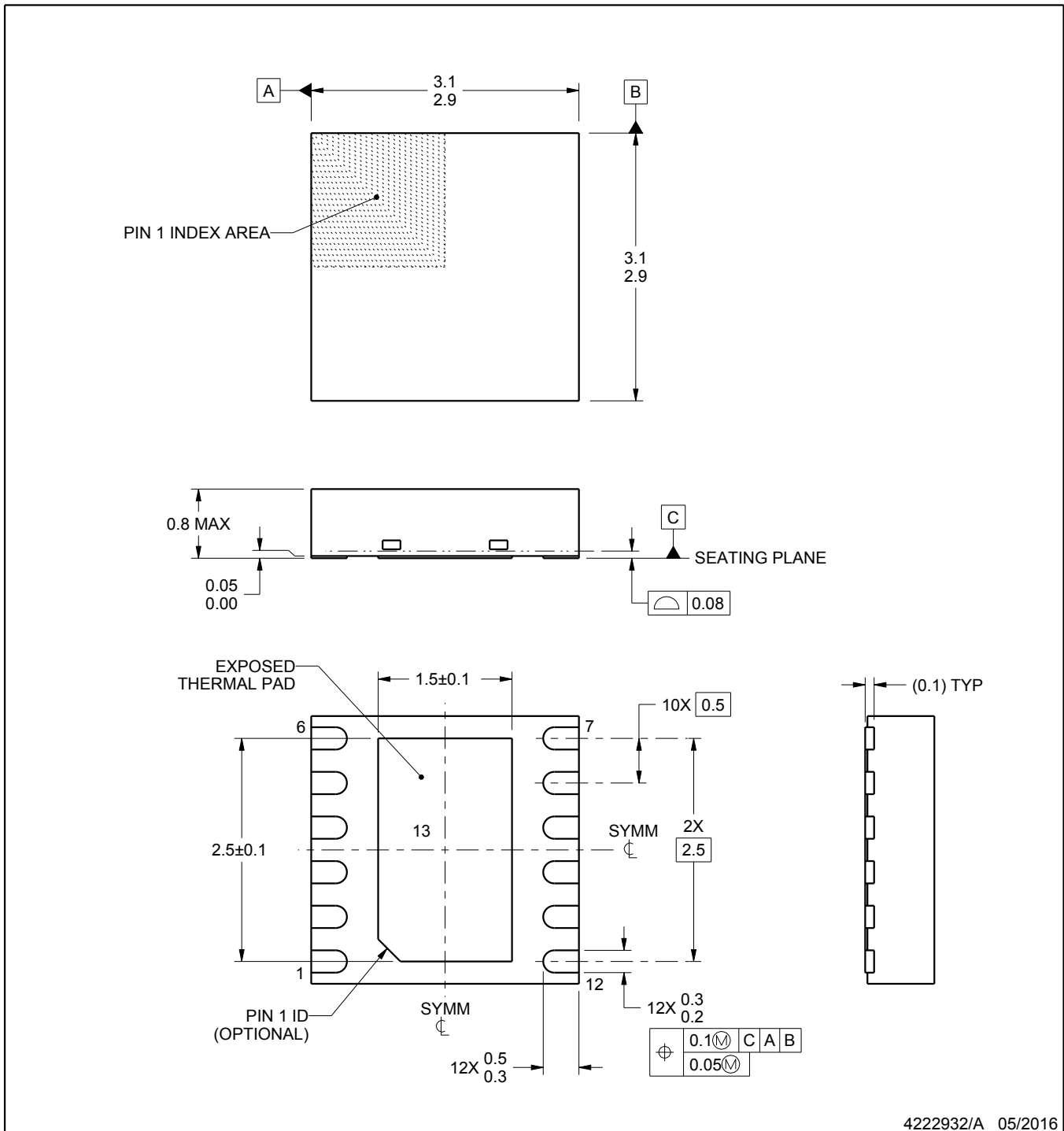
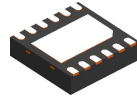

4222932/A 05/2016

NOTES:

1. All linear dimensions are in millimeters. Any dimensions in parenthesis are for reference only. Dimensioning and tolerancing per ASME Y14.5M.
2. This drawing is subject to change without notice.
3. The package thermal pad must be soldered to the printed circuit board for thermal and mechanical performance.

# EXAMPLE BOARD LAYOUT

DRR0012C

WSON - 0.8 mm max height

PLASTIC SMALL OUTLINE - NO LEAD

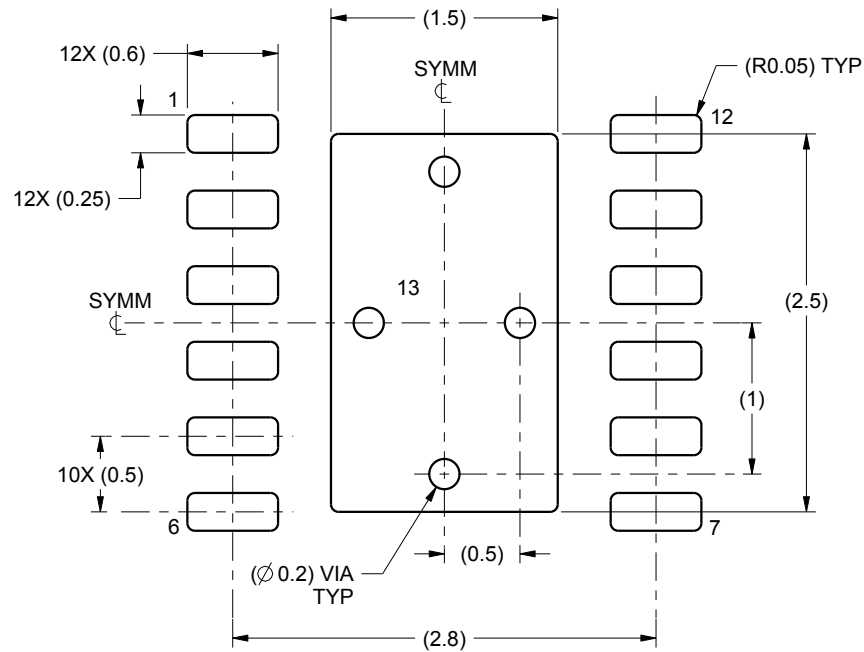

LAND PATTERN EXAMPLE  
SCALE:20X

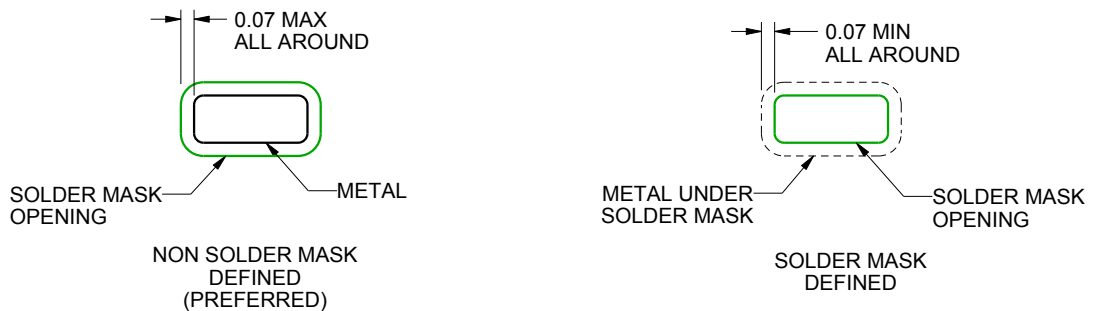

SOLDER MASK DETAILS

4222932/A 05/2016

NOTES: (continued)

4. This package is designed to be soldered to a thermal pad on the board. For more information, see Texas Instruments literature number SLUA271 ([www.ti.com/lit/slua271](http://www.ti.com/lit/slua271)).
5. Vias are optional depending on application, refer to device data sheet. If any vias are implemented, refer to their locations shown on this view. It is recommended that vias under paste be filled, plugged or tented.

# EXAMPLE STENCIL DESIGN

DRR0012C

WSON - 0.8 mm max height

PLASTIC SMALL OUTLINE - NO LEAD

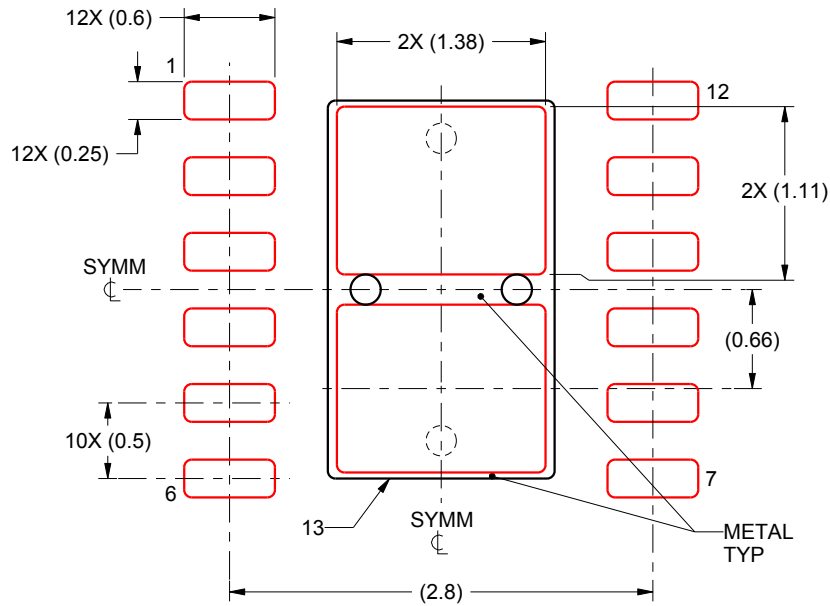

**SOLDER PASTE EXAMPLE**  
BASED ON 0.125 mm THICK STENCIL

EXPOSED PAD 13  
81.7% PRINTED SOLDER COVERAGE BY AREA  
SCALE:20X

4222932/A 05/2016

NOTES: (continued)

6. Laser cutting apertures with trapezoidal walls and rounded corners may offer better paste release. IPC-7525 may have alternate design recommendations.

## 重要声明和免责声明

TI“按原样”提供技术和可靠性数据（包括数据表）、设计资源（包括参考设计）、应用或其他设计建议、网络工具、安全信息和其他资源，不保证没有瑕疵且不做任何明示或暗示的担保，包括但不限于对适销性、某特定用途方面的适用性或不侵犯任何第三方知识产权的暗示担保。

这些资源可供使用 TI 产品进行设计的熟练开发人员使用。您将自行承担以下全部责任：(1) 针对您的应用选择合适的 TI 产品，(2) 设计、验证并测试您的应用，(3) 确保您的应用满足相应标准以及任何其他功能安全、信息安全、监管或其他要求。

这些资源如有变更，恕不另行通知。TI 授权您仅可将这些资源用于研发本资源所述的 TI 产品的应用。严禁对这些资源进行其他复制或展示。您无权使用任何其他 TI 知识产权或任何第三方知识产权。您应全额赔偿因在这些资源的使用中对 TI 及其代表造成的任何索赔、损害、成本、损失和债务，TI 对此概不负责。

TI 提供的产品受 [TI 的销售条款](#) 或 [ti.com](#) 上其他适用条款/TI 产品随附的其他适用条款的约束。TI 提供这些资源并不会扩展或以其他方式更改 TI 针对 TI 产品发布的适用的担保或担保免责声明。

TI 反对并拒绝您可能提出的任何其他或不同的条款。

邮寄地址：Texas Instruments, Post Office Box 655303, Dallas, Texas 75265

Copyright © 2022，德州仪器 (TI) 公司